

MINDEO

uE966 Laser Barcode Scan Engine

User Manual



Version: uE966_UM_EN_V1.1.15

Notice

Make sure you carefully read the following information to ensure that your barcode scan engine is able to perform at the level for which it is designed.

1. All software, including firmware, furnished to the user is on a licensed basis.
2. The right is reserved to make changes to any software or product to improve reliability, function, or design.
3. The material in this manual is subject to change without notice.
4. The manufacturer assumes no responsibility for any loss or claim by third parties which may arise from the use of this manual.
5. Do not throw or drop the scan engine or otherwise subject it to strong impact, which can damage the engine, interrupt program execution, corrupt memory contents, or otherwise interfere with proper operation.

Notes about structure and electric circuit design

1. The engine chassis is electrically connected to ground. It must be isolated from power and ground.
2. Use only non-magnetic screws, or locating pins when mounting the engine. Magnetic screws or pins can cause element/mirror neutral position to change.
3. It is strongly recommended to use a thread locking method, such as a Nylok patch.
4. Do not place magnetic material (e.g. dynamic speakers, ringers, vibrators, inductors, metal parts) within 1 inch of the engine chassis. Evaluate placement of all magnetic or ferrous material during system layout to determine if 1 inch is sufficient.
5. Leave sufficient space to accommodate the maximum size of the engine.
6. **Avoid bending when FFC/FPC cable is installed, so as not to impact the performance of the scan engine. If bending is needed, the flexible PCB is recommended to be used.**
7. Read [3-1 Important notes of installation](#) carefully to learn about dust-proof, moisture-proof design, grounding design and ESD design, non-magnetism design.
8. Read [3-3 Exit window materials](#) carefully to learn about the options of exit window material.
9. Read [3-4 Exit window tilt angle](#) carefully to learn about the exit window tilt angle against the engine.
10. Read [2-1 Electrical interface/Pin assignment](#) carefully to learn about the electrical interface design.
11. Read [2-3 Power management](#) carefully to learn about the information about the power modes and power states. Please refer to [Table 2-2 Waking-up the engine](#), **make sure all wake-up events have been released if a Sleep Power state is expected.**
12. Refer to [7-13 SE_PARAM_SEND](#) and [7-25 UE_PARAM_SEND](#), be noted that frequent permanent changes of parameter value are not recommended due to the limited write-cycles of flash memory. And temporary changes of parameter value will be lost when power removed or when the engine enters Sleep Power state.
13. It's strongly recommended that host uses Pin RTS/CTS to communicate with engine. Read [8-3 Transaction examples](#) and [8-4 SCI transactions notes](#).

Contents

1 Specifications	1
1-1 Technical specifications	1
1-2 Default settings for various types of barcode	3
1-3 Decode zone	4
2 Get started	5
2-1 Electrical interface/Pin assignment	5
2-2 Typical input, output, LDO, and DC/DC circuitries	7
2-3 Power management	8
3 Installation guide	10
3-1 Important notes of installation	10
3-2 Mounting	11
3-3 Exit window materials	12
3-4 Exit window tilt angle	13
3-5 Exit window positioning	14
4 Timing	15
4-1 Timing characteristics	15
4-2 Timing waveforms	16
5 Demonstration of engine operation	18
5-1 Case 1: Beep via RXD/TXD regardless PWRDWN status	18
5-2 Case 2: Beep after pulling down WAKE pin	19
5-3 Case 3: Request revision via RXD/TXD	20
5-4 Case 4: Start decode after pulling down CTS pin	21
5-5 Case 5: Start decode after pulling down TRIG pin	22
6 Parameter menus	23
6-1 Introduction	23
6-2 Instruction: configure engine by scanning configuration barcodes	24
6-3 UART interface	25
6-4 Trigger mode & some global settings	27
6-5 Indication	30
6-6 UPC-A	31
6-7 UPC-E	33
6-8 UPC-E1	35
6-9 EAN-13 (ISBN/ISSN)	37
6-10 EAN-8	39
6-11 Code 39 (Code 32, Trioptic Code 39)	41
6-12 Interleaved 2 of 5	43
6-13 Industrial 2 of 5	45
6-14 Matrix 2 of 5	46

6-15 Codabar	47
6-16 Code 128	49
6-17 UCC/EAN 128.....	51
6-18 ISBT 128.....	52
6-19 Code 93	53
6-20 Code 11	54
6-21 MSI/Plessey	55
6-22 UK/Plessey	57
6-23 China Post	58
6-24 GS1 DataBar (GS1 DataBar Truncated).....	59
6-25 GS1 DataBar Limited	60
6-26 GS1 DataBar Expanded.....	61
6-27 G1-G4 & FN1 substitution string setting.....	62
6-28 G1-G4 string position & Code ID position	65
6-29 String transmission.....	66
6-30 SE serial parameters list	68
7 Serial Communication Interface.....	80
7-1 SCI message formats.....	82
7-2 AIM_OFF.....	83
7-3 AIM_ON	84
7-4 BEEP	85
7-5 CMD_ACK.....	87
7-6 CMD_NAK.....	88
7-7 DECODE_DATA	90
7-8 EVENT	92
7-9 LED_OFF	93
7-10 LED_ON.....	94
7-11 SE_PARAM_DEFAULTS	95
7-12 SE_PARAM_REQUEST.....	96
7-13 SE_PARAM_SEND	98
7-14 SE_CUSTOM_DEFAULTS	100
7-15 REQUEST_REVISION.....	102
7-16 REPLY_REVISION	103
7-17 SCAN_DISABLE	104
7-18 SCAN_ENABLE	105
7-19 START_DECODE	106
7-20 STOP_DECODE	107
7-21 SLEEP	108
7-22 WAKEUP	109

7-23 UE_PARAM_DEFAULTS	110
7-24 UE_PARAM_REQUEST	111
7-25 UE_PARAM_SEND.....	113
7-26 UE_CUSTOM_DEFAULTS	115
7-27 MANUFACTURE_INFO_REQUEST	117
7-28 MANUFACTURE_INFO_SEND.....	118
8 SCI transactions	119
8-1 ACK/NAK handshaking	119
8-2 Transfer of decode data	120
8-3 Transaction examples	121
8-4 SCI transactions notes	131
9 Glossary	133
10 ASCII table	134
11 Test chart	135
12 Enable & Disable scanning configuration barcode	137
13 Return default parameters & firmware version	138
14 Configuration alphanumeric entry barcode (as Para. value).....	139
Appendix A: Notes of the substitution of uE serial for SE serial.....	140

1 Specifications

1-1 Technical specifications

Table 1-1 Technical specifications @25°C

Dimensions	Height × Width × Depth: 12.0 mm × 21.6 mm × 15.5 mm (maximum)
Weight	8.00±0.25 g
Cable	Tapered 12-pin flex strip (12 × 0.5 mm)
Indicator interface	To control external Beeper and LED
Interface supported	UART
Scan mode	Good-read off, Momentary, Alternate, Continuous, Host
Programming method	Method I: Manual (scanning special barcode in sequence) Method II: send command via UART interface
Firmware upgrade	Online
Input voltage	3.3±5% VDC
Scanning current	75 mA (typical), 85 mA (maximum)
Standby current	<8 µA
Laser	650 nm laser diode
Scan rate	100±10 scans/second
Scanning angle	±50 °, ±65 °, ±35 °(Skew, Pitch, Roll)
Decode capability	UPC-A, UPC-E, EAN-13, EAN-8, ISBN/ISSN, Code 39, Code 39 full ASCII, Code 32, Trioptic Code 39, Interleaved 2 of 5, Industrial 2 of 5 (Discrete 2 of 5), Matrix 2 of 5, Codabar (NW7), Code 128, Code 93, Code 11 (USD-8), MSI/Plessey, UK/Plessey, UCC/EAN 128, China Post, GS1 DataBar (formerly RSS) variants
Max. resolution	4 mil (1 mil = 0.0254 mm)
Decoding depth	4 mil: 40 mm (50±10 - 90±10 mm) 5 mil: 65 mm (50±10 - 115±10 mm) 10 mil: 240 mm (20±10 - 260±20 mm) 15 mil: 350 mm (30±10 - 380±20 mm) 20 mil: 445 mm (45±10 - 490±30 mm) 30 mil: 660 mm (40±10 - 700±30 mm) 55 mil: 780 mm (80±10 - 850±100 mm) See 1-3 Decode zone for reference.
Temperature	Operating: -10 °C to 60 °C (-4 °F to 140 °F); Storage: -40 °C to 70 °C (-40 °F to 158 °F)
Humidity	5% to 90% (non-condensing)
Mechanical vibration	IEC60068-2-6 Un-powered engine withstands a random vibration along each of the X, Y and Z axes for a period of one hour per axis, define as follows: 20 to 80 Hz Ramp up to 0.04 G ² /Hz at the rate of 3 dB/oct 80 to 350 Hz 0.04 G ² /Hz 350 to 2000 Hz Ramp down at the rate of 3 dB/oct
Mechanical shock	IEC60068-2-27 Shock pulse: 0.5 ms, Maximal acceleration: 1500 G, Shock direction & time: ±X-axis, ±Y-axis, ±Z-axis, 3 times for each direction, total of 18 times.

Laser safety	EN60825-1-2007, Class 1
ESD protection	EN55024 (IEC61000-4-2, contact discharge: ± 4 KV, air discharge: ± 8 KV), IEC61000-4-4, IEC61000-4-5, IEC61000-4-6, IEC61000-4-11
RF immunity	IEC61000-4-3, 10 V/m
Power emission	EN55022, class B; EN61000-3-2; IEC61000-3-3
Artificial light immunity	100,000 lux

1-2 Default settings for various types of barcode

Table 1-2 Default settings

Code type	Read enable	Check digit verification	Check digit transmission	Min. code length	Proprietary code ID	AIM code ID
UPC-A	√	√	√	(12) ²	A]Em
UPC-E	√	√	√	(8) ²	D]Em
UPC-E1	√	√	√	(8) ²	D]Em
EAN-13	√	√	√	(13) ²	A]Em
EAN-8	√	√	√	(8) ²	C]Em
ISBN/ISSN ¹	√	√	√	(13) ²	B]Em
Code 39	√	-	-	1	M]Am
Interleaved 2 of 5	√	-	-	6	I]Im
Industrial 2 of 5 (Discrete 2 of 5)	-	-	-	4	H]Im
Matrix 2 of 5	√	-	-	6	X]Im
Codabar (NW7)	√	-	-	4	N]Fm
Code 128	√	√	-	1	K]Cm
UCC/EAN 128	√	√	-	1	K]Cm
ISBT 128	√	√	-	1	K]Cm
Code 93	√	√	-	1	L]Gm
Code 11 (USD-8)	-	√	-	4	V	-
MSI/Plessey	-	-	-	4	O]Mm
UK/Plessey	√	√	-	1	U]Mm
China Post	√	-	-	(11) ²	T]Im
GS1 DataBar	√	-	-	(16) ²	R]em
GS1 DataBar Truncated ³	√	-	-	(16) ²	R]em
GS1 DataBar Limited	√	-	-	(16) ²	R]em
GS1 DataBar Expanded	√	-	-	1	R]em

Note: ¹ The settings for ISBN/ISSN and EAN-13 must be the same except the code ID.

² Fixed-length barcodes.

³ The settings for GS1 DataBar Truncated and GS1 DataBar must be the same.

1-3 Decode zone

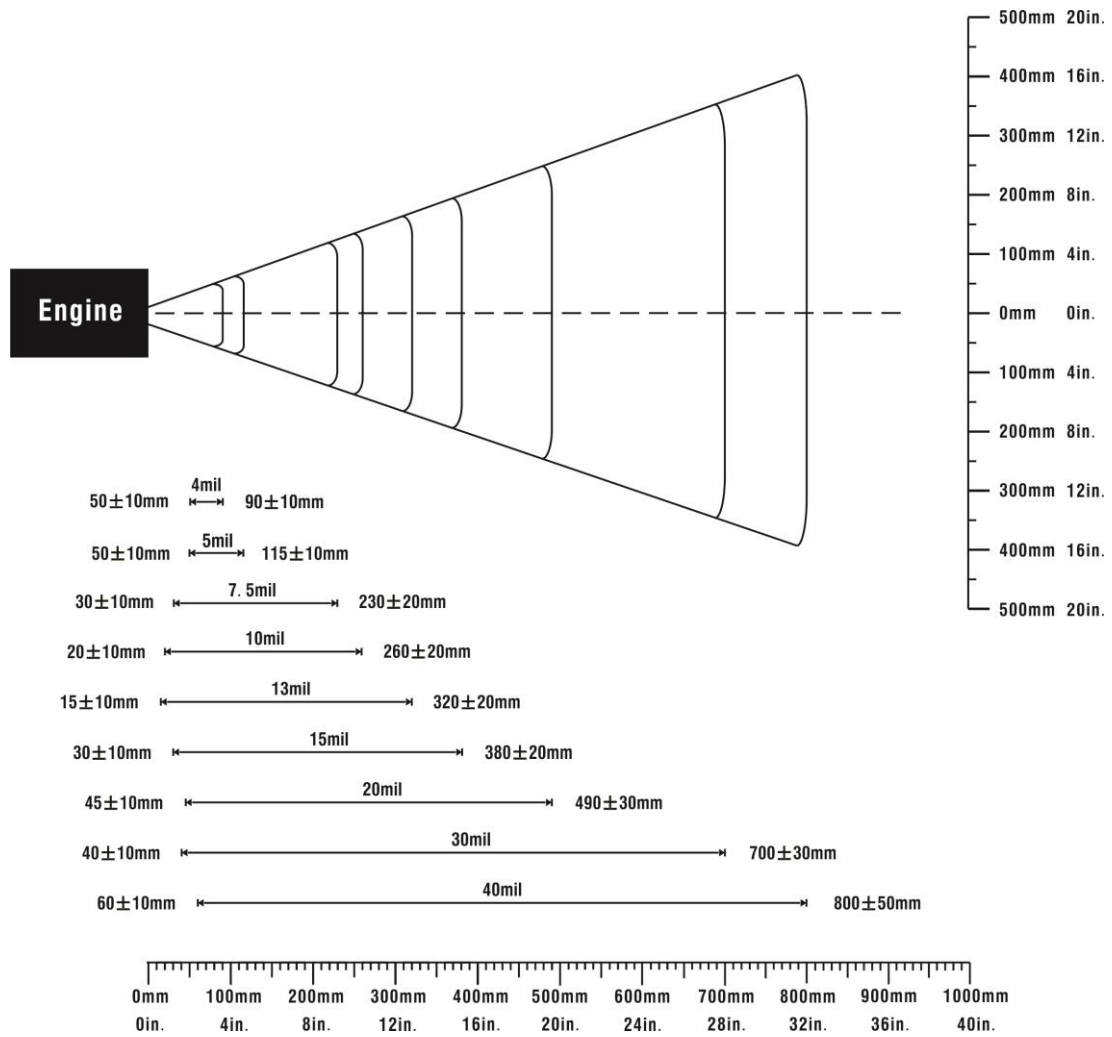

Figure 1-1 Decode zone @25°C

Table 1-3 Description of barcode patterns applied in Figure 1-1

Resolution	Barcode type	Wide-narrow element ratio	Barcode content	Contrast
4.0 mil	Code 39	2.5:1	ABCDEFGH	80%
5.0 mil	Code 39	2.5:1	ABCDEFGH	80%
7.5 mil	Code 39	2.5:1	ABCDEF	80%
10 mil	Code 39	2.5:1	ABCDE	90%
13 mil	100% UPC	-	12345678905	90%
15 mil	Code 39	2.5:1	ABCD	80%
20 mil	Code 39	2.2:1	123	80%
40 mil	Code 39	2.2:1	AB	80%
55 mil	Code 39	2.2:1	CD	80%

2 Get started

2-1 Electrical interface/Pin assignment

The engine provides a low profile ZIF 12-pin connector to connect to a 0.5 mm × 12 position FFC/FPC cable.

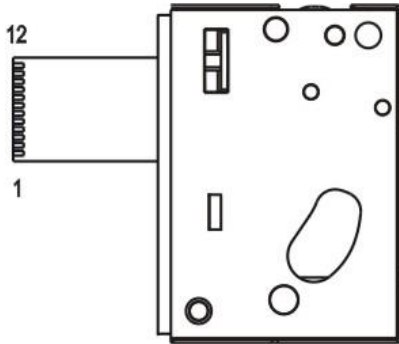

Figure 2-1 Top view

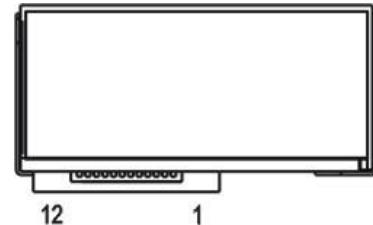

Figure 2-2 Backward view

Table 2-1 lists the pin assignments of the engine.

Table 2-1 Electrical interface/Pin assignment

Pin No.	Pin/Signal Name	Type	Description
1	Flash_DWLD*	Input	Flash download. Pull low for download.
2	VBATT	Input	Power supply: 3.15 to 3.45 VDC.
3	GND	Input	Ground: 0V reference.
4	RXD	Input	Received data: Serial data receive input port.
5	TXD	Output	Transmitted data: Serial data transmit output port.
6	CTS*	Input	Clear-to-send: Serial port handshaking line (input).
7	RTS*	Output	Request-to-send: Serial port handshaking line (output).
8	PWRDWN	Output	Power down ready: When high, the engine is in Low Power mode.
9	BPR*	Output	Beeper*: Low current beeper output.
10	DLED*	Output	Decode LED: Low current decode LED output.
11	WAKE*	Input	Wake up: When engine is in Low Power mode, the falling edge of this pin awakens the engine. ^{Note 1}
12	TRIG*	Input	Trigger: Hardware triggering line, Driving this pin low causes the engine to start a scan and decode session.

Notes:

1. The falling edge of anyone of the pin RXD, CTS*, WAKE* and TRIG* can awaken the engine.
2. *=logic low. Signal names with the "*" modifier are asserted when at the ground level. Signals names without the "*" modifier are asserted when at the positive supply voltage level.

A diagram of an interconnection between a scan engine and a host is shown below.

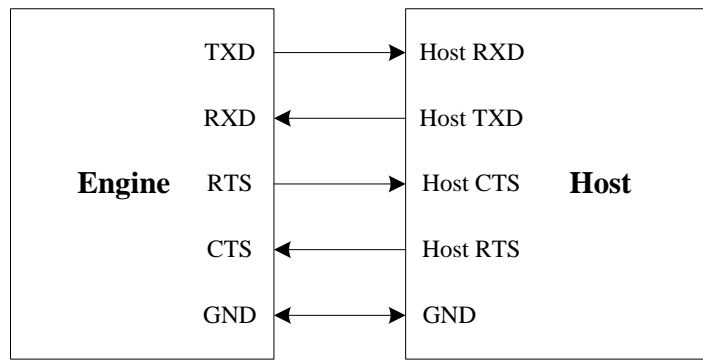
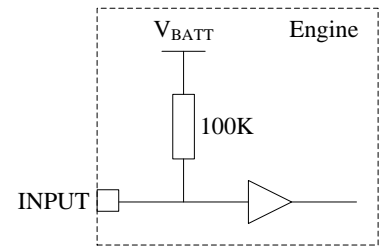
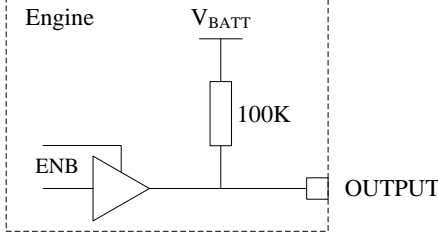
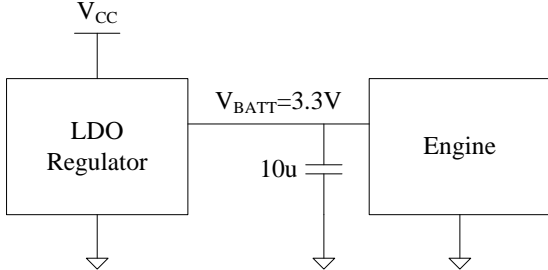
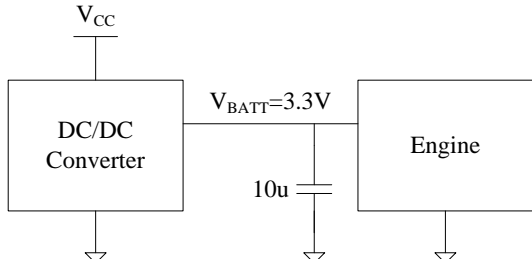

Figure 2-3 Engine and Host interconnection via RS232

2-2 Typical input, output, LDO, and DC/DC circuitries

<p>Input: Each input IO pin is internally pulled up by a 100K resistor.</p> <p>$V_{BATT}=3.3V$.</p> <table border="1" data-bbox="199 403 446 515"> <thead> <tr> <th></th> <th>min.</th> <th>max.</th> </tr> </thead> <tbody> <tr> <td>V_{inL}</td> <td>-0.3V</td> <td>0.7V</td> </tr> <tr> <td>V_{inH}</td> <td>2.4V</td> <td>3.6V</td> </tr> </tbody> </table>		min.	max.	V_{inL}	-0.3V	0.7V	V_{inH}	2.4V	3.6V	
	min.	max.								
V_{inL}	-0.3V	0.7V								
V_{inH}	2.4V	3.6V								
<p>Output: When in sleep state, the tri-state gate outputs high impedance, and each output IO is only pulled up by a 100K resistor.</p>										
<p>External LDO circuitry: It is recommended to apply low noise LDO (low dropout voltage) regulator.</p>										
<p>External DC/DC circuitry: It is recommended to apply a DC/DC converter with high switching frequency (>1MHz) and low output ripple (<50mV).</p>										

2-3 Power management

The scan engine has two power states (**Awake** and **Sleep**) and two power modes (**Continuous** and **Low**).

✚ State machine of power management

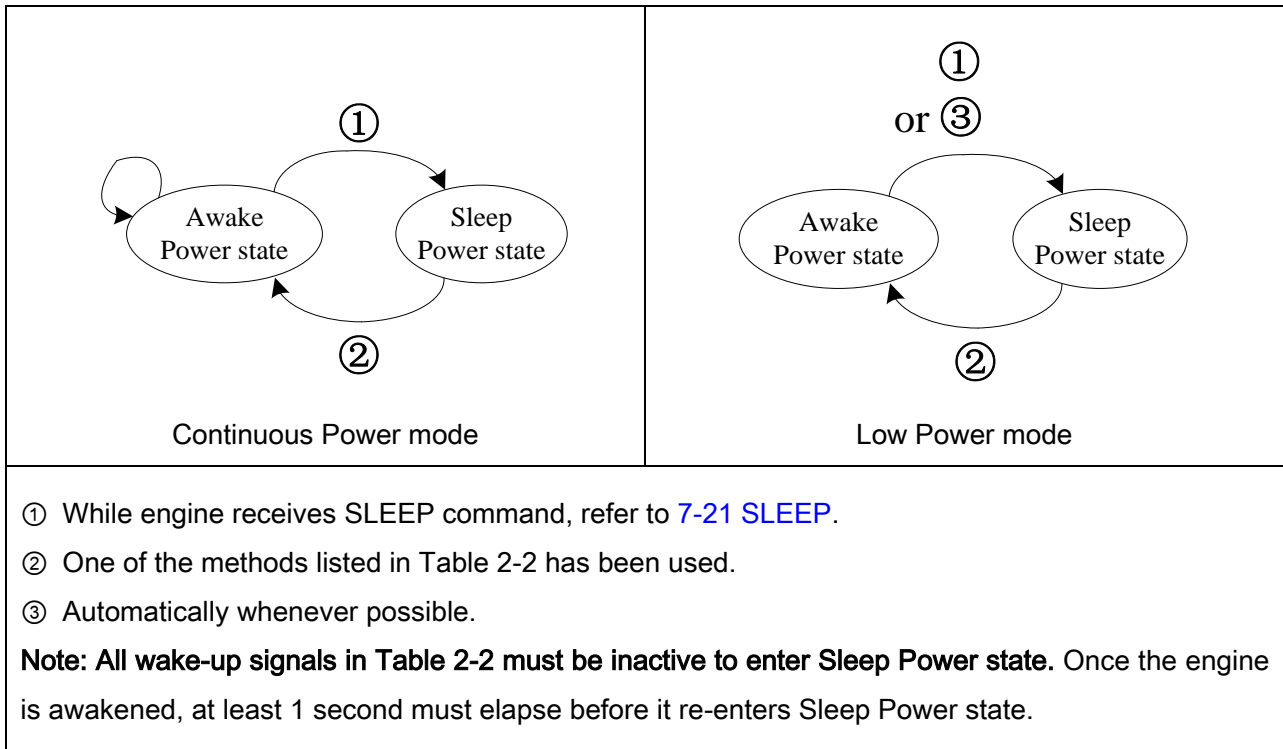

Figure 2-4 State machine of power management

Table 2-2 Waking-up the engine

Signal	State to Wake-up
WAKE*	Low
TRIG*	Low
CTS*	Low
RXD	Send WAKEUP (0x00) command, refer to 7-22 WAKEUP .
Signal names with the "*" modifier are asserted when at the ground level.	
Signal names without the "*" modifier are asserted when at the positive supply voltage level.	

✚ Power states

The engine has two power states: **Awake Power state** and **Sleep Power state**. When the engine is in Low Power mode, the engine will automatically switch to the Sleep Power state whenever possible.

When the engine is in the Sleep Power state, the PWRDWN signal (see [Table 2-1 Electrical interface/Pin assignment](#)) is asserted. The host uses this signal to remove power from the engine. **Do not remove power without using this signal since the PWRDWN signal is the only signal to indicate that the engine is not transmitting, receiving, decoding, or writing data to flash memory.**

Power modes

The scan engine has two power modes: **Continuous Power mode** and **Low Power mode**. Power modes are controlled by the Power Mode parameter (0x80, see [Table 6-1 SE serial standard parameters](#)). The switch between two modes only can be made by command, refer to [7-13 SE_PARAM_SEND](#).

In Continuous Power mode, the scan engine remains in the Awake Power state after each decode-tempt unless it receives a SLEEP command (refer to [Figure 2-4 State machine of power management](#)).

In Low Power mode, the scan engine enters into a low-power-consumption Sleep Power state whenever possible (provided all waking-up engine methods are not active, refer to [Table 2-2 Waking-up the engine](#)). This makes the Low Power mode more suitable for battery powered applications. The engine must be awakened from the Sleep Power state before performing any functions.

3 Installation guide

3-1 Important notes of installation

This section provides information for mounting and installing the engine, including physical and electrical considerations and recommended window properties.

Grounding

The engine chassis is connected to GROUND. If you are installing the engine to a hot or powered host, you must isolate the two. The best integration practice is to avoid ground loops wherever possible. There is a potential for creating a ground loop by grounding the engine chassis to the ground of the system in which the engine is being integrated.

If non-magnetic metallic screws are used, shoulder washers must be used to isolate the screws from the host. Non-metallic screws may also be used if mechanical considerations permit.

ESD

The engine is protected from ESD events that may occur in an ESD-controlled environment. Always exercise care when handling the module. Use grounding wrist straps and handle in a properly grounded work area.

Environment

The engine must be sufficiently enclosed to prevent smoke, dust particles and moisture from gathering on the mirrors, laser lens, and the photodiode. Dust and other external contaminants will eventually cause degradation in unit performance. The performance of engine is not guaranteed when used in an exposed application.

Magnetism

Mounting screws and locating pins must be non-magnetic material. Do not place any magnetic material within 1 inch/ 2.54 cm of the chassis without testing.

3-2 Mounting

There are two mounting holes (M1.6) and two locator holes ($\Phi 1.2$) on the top of the chassis and it is shown in Figure 3-1.

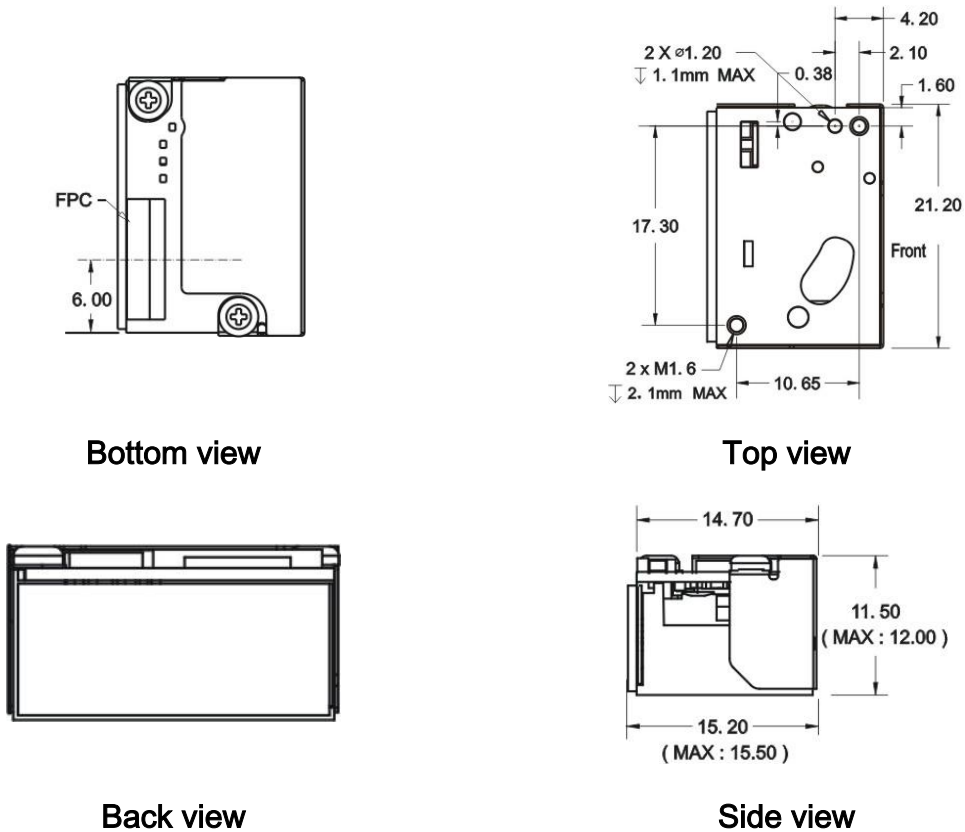

Figure 3-1 Mounting diagram

Notes:

- 1) Chassis is electrically connected to ground and must be isolated from VCC.
- 2) Mounting screws and locating pins must be non-magnetic material. Do not place any magnetic material within 1 inch of the chassis without testing.
- 3) Dimensions are mm.

3-3 Exit window materials

Many window materials that look perfectly clear to the eye can contain stresses and distortions which affect the laser beam and reduce scan engine performance. Following are the description of three popular exit window materials:

- 1) Poly-methyl Methacrylic (PMMA): Also known as Cell Cast Acrylic, and is relatively soft.
- 2) Allyl Diglycol Carbonate (ADC): Also known as CR-39.
- 3) Chemically tempered float glass.

Among these three materials, the chemically tempered float glass is a hard material which provides the most excellent scratch and abrasion resistance. Note that the structure design must be well considered to pass drop test.

3-4 Exit window tilt angle

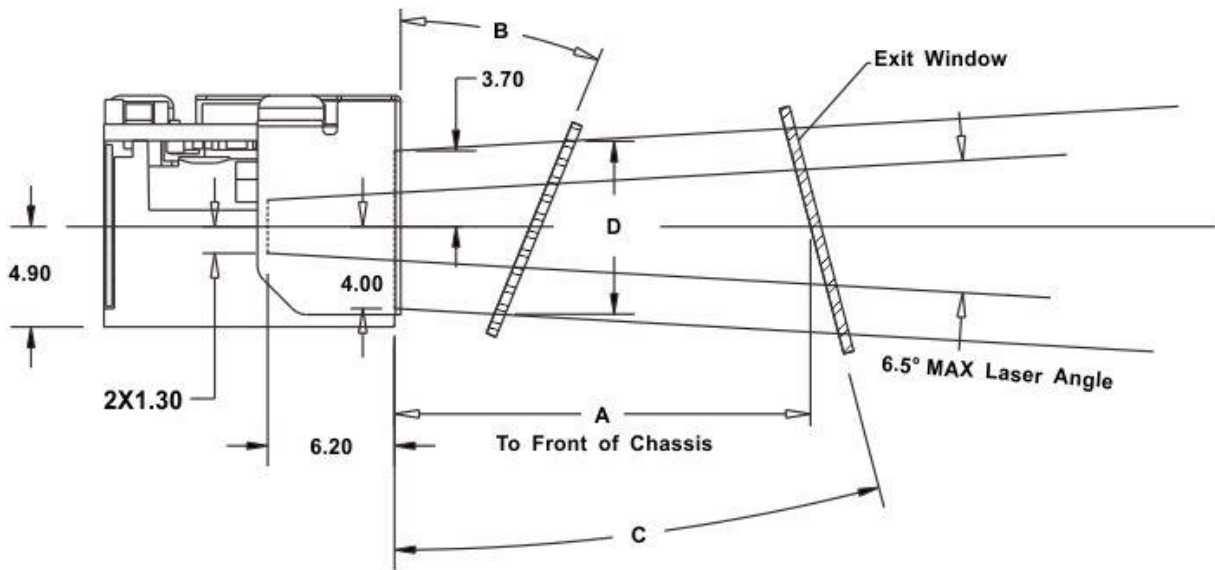

Figure 3-2 Exit window tilt angle

Table 3-1 Exit window distance from engine: 0.15 in – 2.00 in (3.8 mm – 50.8 mm)

A	0.15/3.8	0.16/4.0	0.18/4.5	0.2/5.0	0.22/5.5	0.24/6.0	0.25/6.35
B	36.0°	35.0°	32.5°	31.0°	29.0°	27.5°	26.5°
C	36.0°	35.0°	33.0°	31.5°	29.5°	28.0°	27.0°

A	0.26/6.5	0.28/7.0	0.31/8.0	0.36/9.0	0.39/10.0	0.48/12.0	0.50/12.7
B	26.0°	25.0°	22.5°	20.5°	19.0°	17.0°	16.5°
C	26.5°	25.5°	23.0°	21.5°	20.0°	17.5°	17.0°

A	0.55/14.0	0.75/19.0	1.00/25.4	1.25/31.8	1.50/38.0	1.75/44.5	2.00/50.8
B	15.0°	12.0°	10.0°	9.0°	8.0°	7.5°	7.0°
C	16.0°	12.5°	10.0°	9.0°	8.0°	7.5°	6.7°

Note:

A: Distance from Scan Engine on center line (in/mm);

B: Minimum Window Positive Tilt (degrees);

C: Minimum Window Negative Tilt (degrees).

3-5 Exit window positioning

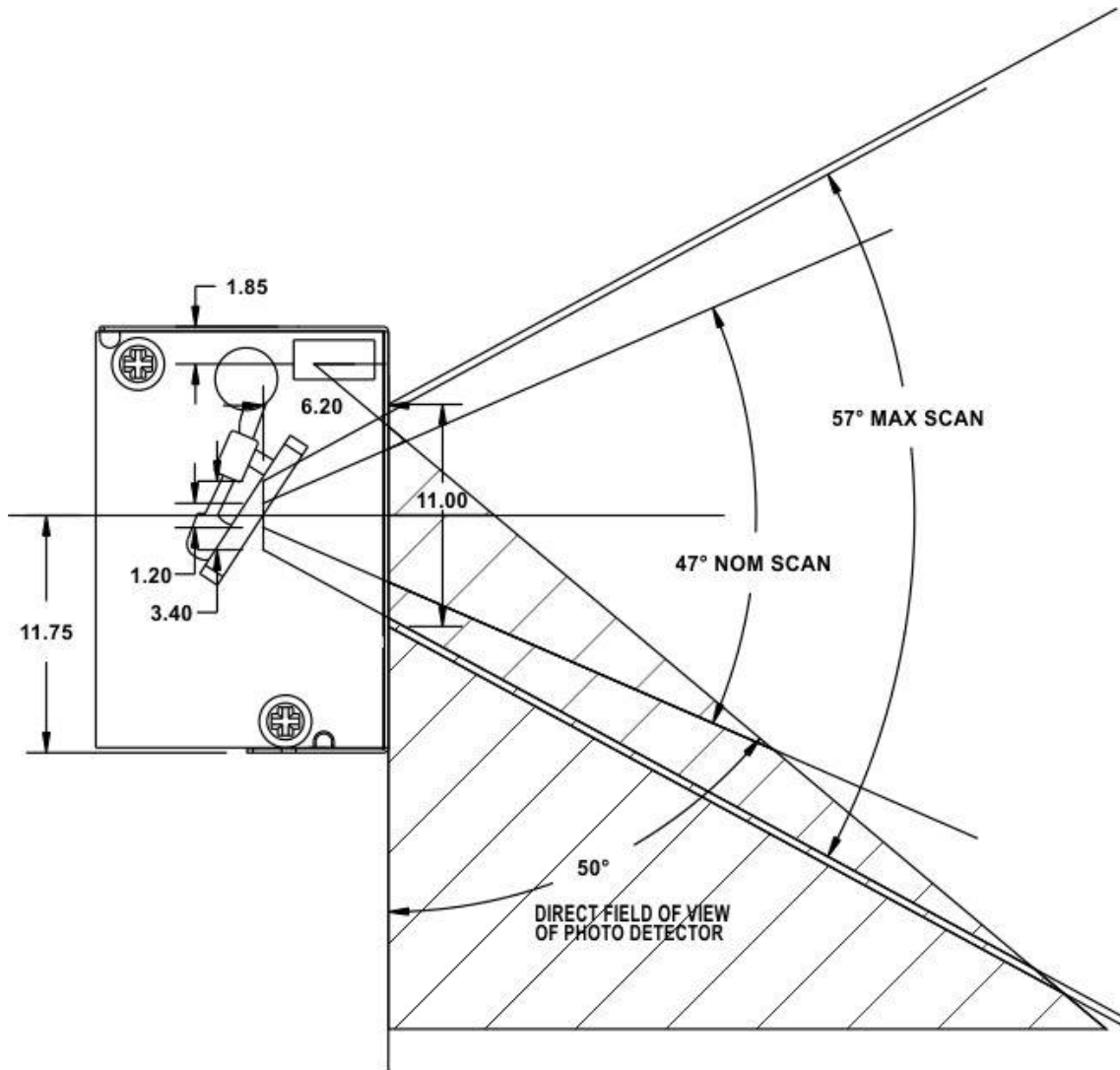

Figure 3-3 Exit window positioning

4 Timing

4-1 Timing characteristics

Timing characteristics are shown in Table 4-1.

Table 4-1 Timing characteristics

Type of barcode	Parameter	Conditions	Min.	Typ.	Max.	Unit
General characteristics						
t_f	High to low fall time	$C_L=50\text{pf}$			1.0	us
t_r	Low to high rise time	$C_L=50\text{pf}$			1.0	us
UART						
t_{rlcl}	RTS low to CTS low		0		25	ms
t_{clbl}	CTS low to first start bit				Note 1	
T_{blbl_cr}	Byte to byte delay	With CTS/RTS control			990	ms
t_{rhrh}	End of the packet to RTS				Note 2	ms
Trigger timing						
t_{trig_l}	Trigger low level hold time		20			ms
t_{trig_h}	Trigger high level hold time		25			ms
t_{dbt}	Trigger de-bounce time				1.1	ms
Beeper timing						
$f_{beeping}$	Beeping frequency		1220		3770	Hz
t_{bpd}	Beeping duration		0	75	2500	ms
LED timing						
t_{lod}	LED On Duration	LED Pin output Low	0	1.0	9.9	sec
Power up timing						
t_{pw_rise}	VIN rise time				10	ms
Wake up timing						
t_{aw2fo}	From wake up to full operation				20	ms
t_{fo2trl}	Full operation to trigger low		0		1	s
t_{fo2rsd}	Full operation to receive command		0		1	s

Note 1: The host RTS may be held low indefinitely to prevent the engine from transmitting.

Note 2: The host RTS should be released as soon as possible after transmitting so that the engine can process next scanning.

4-2 Timing waveforms



Figure 4-1 General characteristics

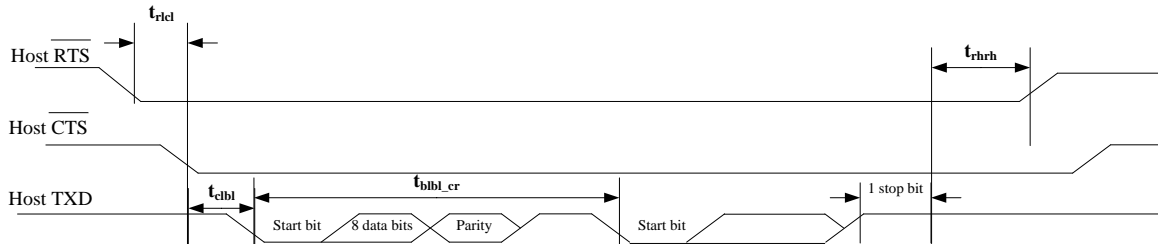

Figure 4-2 Serial I/O timing

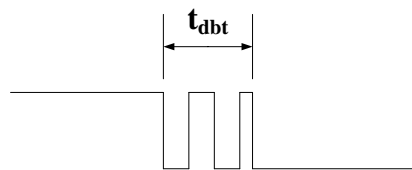

Figure 4-3 Trigger de-bounce timing

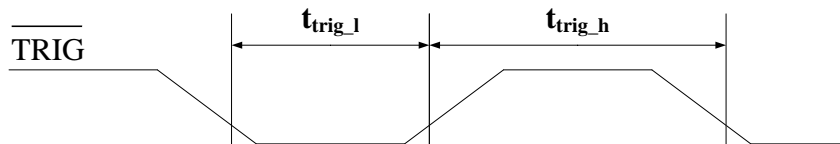

Figure 4-4 Hardware trigger timing

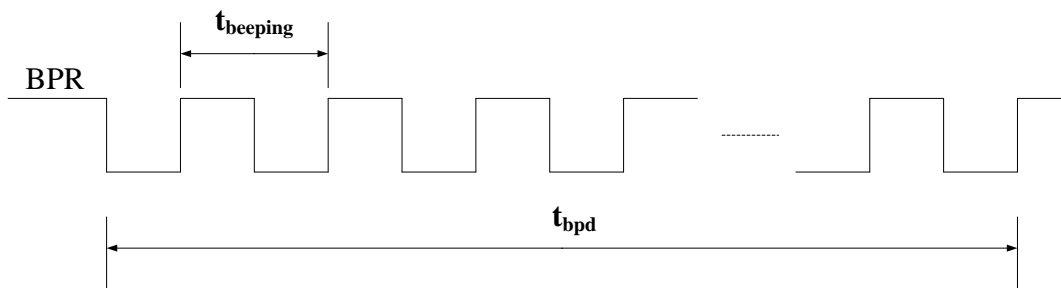

Figure 4-5 Beeper timing

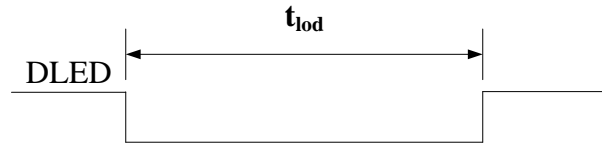

Figure 4-6 LED ON timing

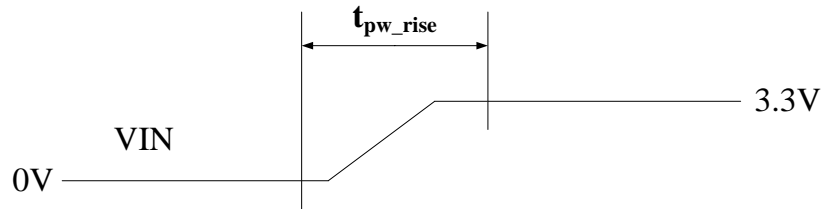

Figure 4-7 VIN rise timing

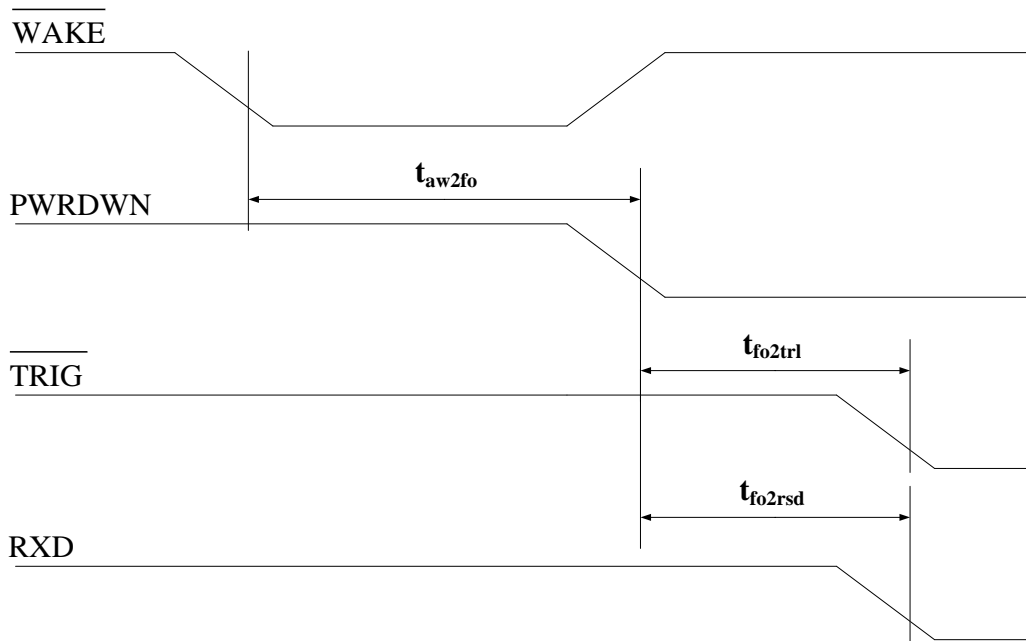

Figure 4-8 Wake-up timing

5 Demonstration of engine operation

By default, the engine will automatically enter **Sleep Power state** if the **TRIG/CTS/WAKE** pin is not pulled down and no data is received via **RXD** within 1 second. The following cases demonstrate how to operate an engine quickly and easily.

5-1 Case 1: Beep via RXD/TXD regardless PWRDWN status

It is quite often that the host controls the engine with **RXD** and **TXD** only regardless **PWRDWN** status. It is recommended that host sends a sequence of Nulls before sending a command to the engine as demonstrated in Figure 5-1. This can guarantee that the engine can accept a command (e.g. **BEEP**) whatever it is in **Awake Power state** or **Sleep Power state** (See [2-3 Power management](#)).

- 1) Host sends a sequence of Nulls within duration T.
- 2) After more than 20 ms and within 1 second, host sends a BEEP command.
- 3) After receiving the command, engine returns an ACK command and its **BPR** pin will output signals to drive an external beeper.

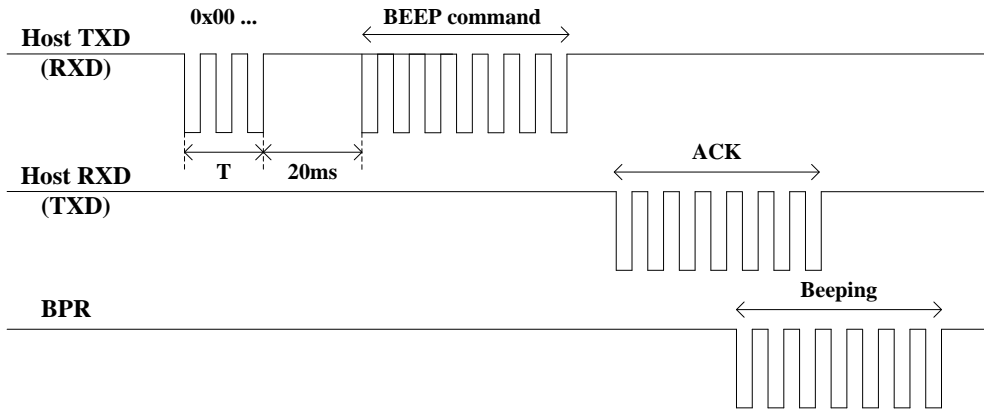

Figure 5-2 Beep timing via RXD/TXD

Note:

- 1) It is required that the duration T must be greater than 3 ms.
- 2) The related number of Null associated with baud rate is listed in Table 5-1.

Table 5-1 Related number of Null associated with baud rate

Baud rate	Related number of Null (0x00)
1200	2
2400	2
4800	2
9600	3
19200	6
38400	9

5-2 Case 2: Beep after pulling down WAKE pin

Assuming that the engine is in Low Power mode, host pulls down the **WAKE** pin to awaken the engine and then sends a **BEEP** command.

- 1) Host pulls down the WAKE pin.
- 2) After more than 20 ms and within 1 second, host sends a BEEP commands, e.g. with the format of 0x05 0xE6 0x04 0x00 0x00 0xFF 0x11.
- 3) After receiving the command, engine returns an ACK command (0x04 0xD0 0x00 0x00 0xFF 0x2C) and its BPR pin will output signals to drive an external beeper.

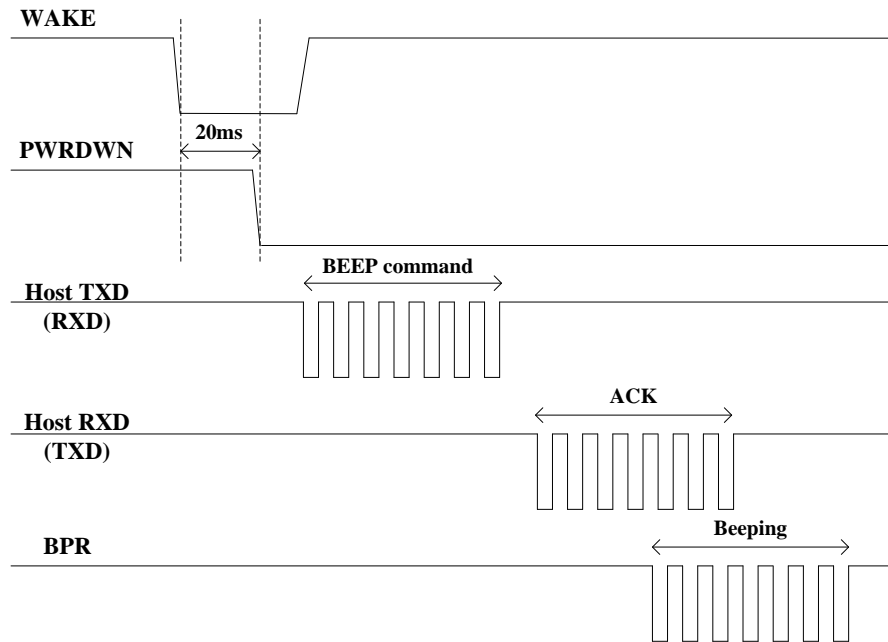

Figure 5-2 Wake and beep timing

5-3 Case 3: Request revision via RXD/TXD

Assuming that engine is in Low Power mode, host sends 0x00 to awaken the engine and then sends a **REQUEST_REVISION** command to ask for software version information.

- 1) Host sends 0x00 via its Host TXD.
- 2) After more than 20 ms and within 1 second, host sends a **REQUEST_REVISION** command (0x04 0xA3 0x04 0x00 0xFF 0x55).
- 3) After receiving the command, engine responds with **REPLY_REVISION** packet which contains firmware version information.

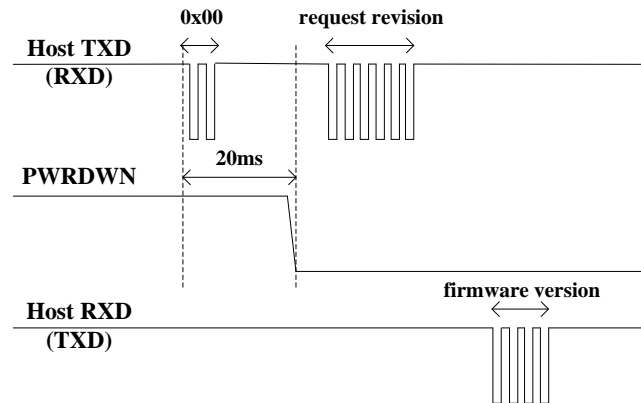

Figure 5-3 REQUEST_REVISION timing

5-4 Case 4: Start decode after pulling down CTS pin

Assuming that engine is in Low Power mode, host pulls down engine's **CTS** pin to awaken engine and then sends a **STRAT_DECODE** command.

- 1) Host pulls down the CTS pin.
- 2) After more than 20 ms and within 1 second, host sends a Host (Trigger mode) command (0x07 0xC6 0x04 0x08 0x00 0x8A 0x08 0xFE 0x95) to switch the trigger mode to be Host mode. If engine currently operates in Host mode, step 3.2 and 3.3 can be ignored.
- 3) After receiving the command, engine returns an ACK command (0x04 0xD0 0x00 0x00 0xFF 0x2C).
- 4) Host sends a SCAN_ENABLE command (0x04 0xE9 0x04 0x00 0xFF 0x0F) within 1 second.
- 5) After receiving the command, engine returns an ACK command.
- 6) Host sends a STRAT_DECODE command (0x04 0xE4 0x04 0x00 0xFF 0x14) within 1 second.
- 7) After receiving the command, engine returns an ACK command and then turns on laser and then decodes.

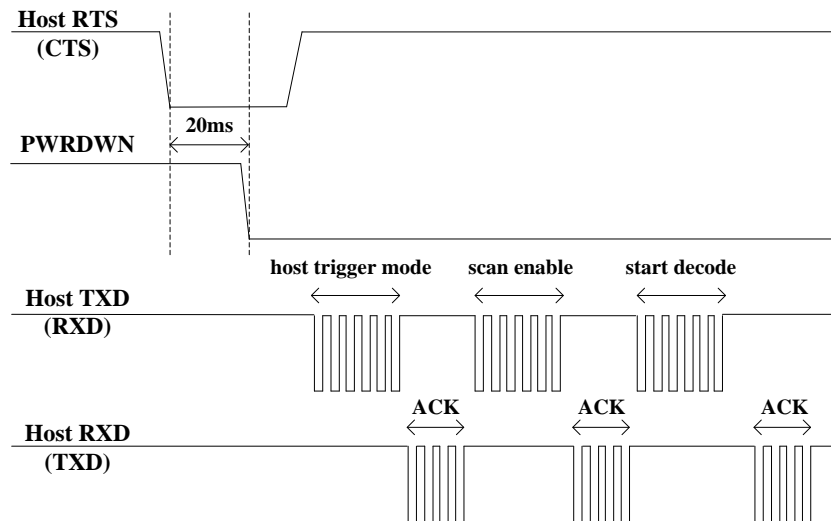

Figure 5-4 STRAT_DECODE timing

5-5 Case 5: Start decode after pulling down TRIG pin

Assuming that engine is in Low Power mode, host pulls down TRIG pin to awaken engine to decode.

- 1) Host keeps pulling down the TRIG pin for at least 20 ms.
- 2) After about 20 ms, engine awakes from Low Power mode.
- 3) Then engine starts up the motor and turns on the laser to decode. The laser will be turned off if time-out is reached or engine succeeds in decoding a barcode.

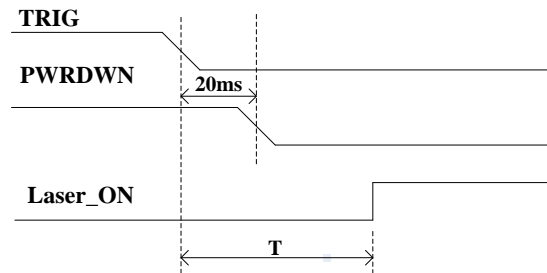

Figure 5-5 TRIG pulled down to start decode timing

Note: $60\text{ ms} \leq T \leq 120\text{ ms}$. The interval T depends on the status of each motor inside the engine.

6 Parameter menus

6-1 Introduction

This section describes the programmable parameters, provides barcodes for programming, and hexadecimal equivalents for host parameter programming through SCI.

The engine is shipped with the factory default settings as described in this chapter. These factory-default-settings values are stored in flash memory and are preserved even when the engine is powered down. Changes to the factory default values can be stored as custom defaults. These values are also stored in flash memory and are preserved even when the engine is powered down.

There are two methods to change the parameter values as described following.

- ✚ Scan the appropriate barcodes as the example shown in [6-2 Instruction: configure engine by scanning configuration barcodes](#). The new values replace the existing memory values.
- ✚ Referring to [13 Return default parameters & firmware version](#), scan the **Write to customer's default setting** (%%WCDF) barcode to set the new values as custom defaults. The factory default or custom default parameter values can be recalled by scanning the **Load uE serial's default setting** (%%DEF), or the **Load SE serial's default setting** (%%SBDEF) barcode, or the **Restore customer's default setting** (%%RSDF) barcode.
- ✚ Send parameters through the scan engine's serial port using the SCI command **SE_PARAM_SEND** or **UE_PARAM_SEND**. The parameters of SE and uE serials are described in details in later sections of this chapter. Instructions for changing parameter value using this method can be found in [7 Serial Communication Interface](#).

6-2 Instruction: configure engine by scanning configuration barcodes

Throughout the configuration barcode menus, the factory default settings are indicated with asterisks (*).

The steps of configuration are:

- Scan the **SETUP** barcode on the parameter setting part.
- Enter the option mode by scanning the **Parameter name** barcode.
- To the right of the option barcode, the necessary alphanumeric inputs are listed. Scan these alphanumeric entries (see section 14 Configuration alphanumeric entry barcode (as Para. value)) individually as **Para. value**.
- Scan the **END** barcode, listed on the bottom of each parameter setting part.

Notes that only one parameter can be setup at each time.

Example: to set **Flow control** to be None.

Steps: Scan the following barcodes in order.

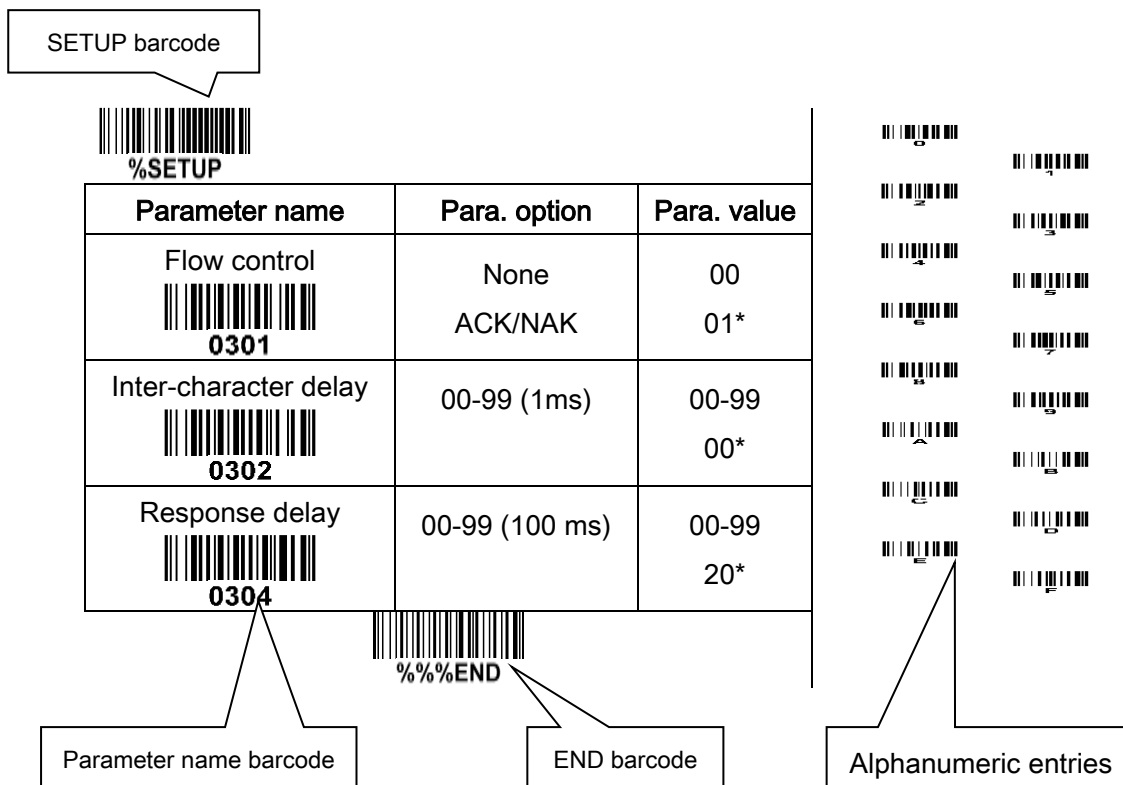

Figure 6-1 Set **Flow control** to be None

6-3 UART interface

Flow control:

None- No software flow control.

ACK/NAK-When this option is selected, after transmitting data, the engine expects either an ACK (acknowledge) or NAK (not acknowledge) response from the host. If the engine does not get a response in this time, it resends its data up to two times before discarding the data and declaring a transmit error. See [7 Serial Communication Interface](#) for more details.

Inter-character delay: This delay is inserted after each data character transmitted.

Response delay: This delay is used for serial communication of the engine when it waits for a handshaking acknowledgment from the host.



%SETUP

uE serial				SE serial	
Parameter name	Para. code	Para. option	Para. value	Parameter (Para. No.)	Para. value
Flow control 0301	0x01 0x2D	None ACK/NAK <small>Note 1</small>	00 01*	Software Handshaking (0x9F)	00 01*
Inter-character delay 0302	0x01 0x2E	00-99 (1 ms)	00*	Intercharacter Delay (0x6E)	00*
Reserved 0303	0x01 0x2F			-	-
Response delay 0304	0x01 0x30	00-99 (100 ms)	00-99 20*	Host Serial Response Timeout (0x9B)	00-99 20*
Baud rate 0305	0x01 0x31	1200 2400 4800 9600 19200 38400 57600 115200 <small>Note 2</small>	02 03 04 05* 06 07 08 09	Baud rate (0x9C)	03 04 05 06* 07 08 09 10
Parity 0306	0x01 0x32	None Odd Even	00* 01 02	Parity (0x9E)	04* 00 01
Data bit 0307	0x01 0x33	8 bits 7 bits	00* 01	-	-
Stop bit 0308	0x01 0x34	One bit Two bits	00* 01	Stop Bit Select (0x9D)	01* 02



%%%END

Note 1: It's strongly recommended that host uses Pin RTS/CTS to communicate with engine. See 8-3, 8-4.

Note 2: If the buad rate is set to 115200, the parameter settings may be failed. It's strongly recommended to make the buad rate lower 115200 if you want to set parameter by command.

6-4 Trigger mode & some global settings

Trigger mode:

Good-read off- The TRIG pin must be pulled down once to activate scanning. The light source of engine stops scanning when there is a successful reading or no code is decoded after the **Stand-by duration** elapsed.

Momentary- The TRIG pin acts as a switch. Pull down the TRIG pin to activate scanning and pull up the TRIG pin to stop scanning. The light source of engine stops scanning when there is a successful reading or no code is decoded after the **Stand-by duration** elapsed.

Alternate- The TRIG pin acts as a toggle switch. Pull down and then pull up the TRIG pin to activate or stop scanning.

Continuous- The engine always keeps scanning, and it does not matter when the TRIG pin is pulled down or duration is elapsed.

Host- A host command issues the triggering signal. The scan engine interprets an actual trigger pull as a momentary triggering option.

Standby duration- The TRIG pin pulled or host command activates scanning. The light source of engine stops scanning when no code is successful decoded after the Stand-by duration elapsed.

Same barcode delay time: This feature is active only when the **Trigger mode** is in **Alternate** or **Continuous** mode. Once a barcode has been scanned and output successfully, the laser beam must be off or moved away from the barcode beyond delay time to active a next scanning on the same barcode. When this parameter is set to be "0xFF", the delay time is indefinite.

Multiple confirm: If this parameter is set to be larger than zero, the engine will require several successful reads of same-decoded-data to confirm a valid reading. The number of successful reads can be different according to different types of barcode. As the number of Multiple confirm gets larger, the engine's aggressiveness decreases. **The number of successful reads** required for different types of barcode is listed below, which is related to the parameter of Multiple confirm.

Table 6-1 The number of successful reads.

Barcode type	Multiple confirm (m)			
	m=0	m=1	m=2	m>=3
EAN-13, EAN-8, UPC-A, Code93, China Post, UK Plessey	2	3	4	m+1
UPC-E, Codebar, Interleaved 2/5, Code39, Industry2/5, Matrix 2/5, Code11, MSI Plessey, UPC-E1	3	4	4	m+1
UCCEAN128, Code128, GS1 DataBar, GS1 DataBar Limited, GS1 DataBar Expand, ISBT 128	1	2	3	m+1

Global Max./Min. code length: These two lengths are defined as the valid range of decoded barcode data length. Make sure that the minimum length setting is no greater than the maximum length setting, or

otherwise the labels of the type of barcode will not be readable. In particular, the same value can be set for both minimum and maximum reading length to force the fixed length barcode decoded.

Notes:

1. Please set the max./min. length for individual barcode in later sections, if a special demand is requested.
2. The number of check digits is included in max./min. code length.
3. These two settings have no effect on the types of barcode with fixed-length, e.g. UPC-A, UPC-E, EAN-13, EAN-8 and China Post.

Global G1-G4 string selection: The engine offer one or two string group for All types of barcode. By setting one or two digits to indicate which string group you want to apply. You may refer to [6-27 G1-G4 & FN1 substitution string setting](#) and [6-28 G1-G4 string position & Code ID position](#).

Example: Group 1 → set 01 or 10. Group 2 and 4 → set 24 or 42.

All valid settings include 00, 01, 02, 03, 04, 10, 11, 12, 13, 14, 20, 21, 22, 23, 24, 30, 31, 32, 33, 34, 40, 41, 42, 43, and 44.

Element amendment: If it is enabled, the engine can read the barcode comprised with bars and spaces in different scale.

Printable character only: If it is enabled, the engine will output the printable characters only, i.e. in ASCII from 20H to 7EH.

Decoder optimization: If it is enabled, the engine will optimize the engine with error correction. This function is not effective for all types of barcode.



uE serial				SE serial	
Parameter name	Para. code	Para. option	Para. value	Parameter (Para. No.)	Para. value
Trigger mode 0401	0x01 0x91	Good-read off Momentary Alternate Continuous Host	00 01* 02 03 04	Trigger Mode (0x8A)	02 (Pulse) 00 (Level) * 05 (Alternate) 04 (Continuous) 08 (Host)
Standby duration 0402	0x01 0x92	01-99 (100ms)	01-99 40*	Laser On Time (0x88)	01-99 (100ms) 30*
Same barcode delay time 0403	0x01 0x93	00-99 (100ms)	00-99 10*	Timeout Between Same Type of barcode (0x89)	00-99 (100ms) 10*
Multiple confirm 0404	0x01 0x94	00-09 (00: no)	00-09 00*	Multi-confirm (0xF2 0x10)	00-09 00*
Global max. code length 0405	0x01 0x95	04-99	04-99 99*	GlobalMaxCodeLength (0xF2 0x11)	04-99 99*
Global min. code length 0406	0x01 0x96	01-99	01-99 04*	GlobalMinCodeLength (0xF2 0x12)	01-99 04*
Global G1-G4 string selection 0407	0x01 0x97	00-44	00-44 00*	GlobalG1G4String Selection (0xF2 0x13)	00-44 00*
Element amendment 0408	0x01 0x98	Disable Enable	00 01*	ElementAmendment (0xF2 0x14)	00 01*
Printable character only 0409	0x01 0x99	Disable Enable	00* 01	PrintableCharacterOnly (0xF2 0x15)	00* 01
Decoder optimization 0410	0x01 0x9A	Disable Enable	00 01*	DecoderOptimization (0xF2 0x16)	00 01*
Reserved 0411	0x01 0x9B			-	-







6-5 Indication

Power-ON alert: After power-on the engine will send a boot up event message to the host. The boot-up event message format is 0x05, 0xF6, 0x00, 0x00, 0x03, 0xFF, 0x02. The detailed event message is described in [7-8 EVENT](#).

LED-ON duration: This parameter can be adjusted for each successful reading.

Beeper indication: After each successful reading, the engine will beep to indicate a good barcode reading.

Beep duration: This parameter can be adjusted for a good reading upon favorite usage.

uE serial				SE serial	
Parameter name	Para. code	Para. option	Para. value	Parameter (Para. No.)	Para. value
Power-ON alert  0501	0x01 0xF5	Disable Enable	00* 01	Boot up Event (0xF0 0x02)	00* 01
LED-ON duration  0502	0x01 0xF6	00-99 (100ms)	00-99 10*	LedOnDuration (0xF2 0x20)	10*
Beeper indication  0503	0x01 0xF7	Disable Enable	00 01*	Beep After Good Decode (0x38)	00 01*
Beep duration  0504	0x01 0xF8	01-09 (25ms)	01-09 03*	-	- (125ms)

 %%%END

6-6 UPC-A

Read:

Format

System character	Data digits (10 digits)	1 check digit
------------------	-------------------------	---------------

Check digit verification: The check digit verification is optional.

Check digit trans.: By setting Enable, check digit will be transmitted.

Code ID setting: Code ID is a one-or-two-character string used to represent the barcode type upon a succeeding reading. If Code ID transmission is expected, **Code ID transmission** must be set Enable.

Refer to [6-29 String transmission](#) for details.

Insertion group selection: Refer to **Global insertion group selection** of [6-4 Trigger mode & some global settings](#).

Supplement digits: The Supplement digits barcode is the supplemental 2 or 5 characters.

Format

System character	Data digits (10 digits)	Check digit	Supplement digits 2 or 5
------------------	-------------------------	-------------	--------------------------

Truncation/Expansion:

Truncate leading zeros- The leading “0” digits of UPC-A data characters can be truncated when the feature is enabled.

Expand to EAN-13- It extends to 13-digits with a “0” leading digit when the feature is enabled.

Truncate system character- The system character of UPC-A data can be truncated when the feature is enabled.

Add country code- The country code (“0” for USA) can be added when the feature is enabled.



uE serial				SE serial	
Parameter name	Para. code	Para. option	Para. value	Parameter (Para. No.)	Para. value
Read 1101	0x04 0x4D	Disable Enable	00 01*	UPC-A (0x01)	00 01*
Check digit verification 1102	0x04 0x4E	Disable Enable	00 01*	UPC-A CheckDigitVerification (0xF2 0x29)	00 01*
Check digit trans. 1103	0x04 0x4F	Disable Enable	00 01*	Transmit UPC-A Check Digit (0x28)	00 01*
Code ID setting 1104	0x04 0x50	00-FF ₁₆ (ASCII)	00-FF ₁₆ <A>*	UPC-A_CodeID_Setting (0xF2 0x2B)	<A>*
Insert group selection 1105	0x04 0x51	00-44	00-44 00*	UPC-A_InsertGroupSelecti on (0xF2 0x2C)	00-44 00*
Supplement digits 1106	0x04 0x52	None 2 digits 5 digits 2 or 5 digits	00* 01 02 03	Decode UPC/EAN Supplemental (0x10) ^{Note1}	00* FF ₁₆ FF ₁₆ 02
Truncation/Expansion 1107	0x04 0x53	None Truncate leading zeros Expand to EAN-13 Truncate system character Add country code	00* 01 02 03 04	UPC-A Preamble (0x22) ^{Note2}	01* FF ₁₆ FF ₁₆ 00 02
Reserved 1108	0x04 0x54			-	-



Note 1: If uE parameters 1106, 1206, 1306, 1406 and 3406 are all 0x00, the SE serial parameter (Decode UPC/EAN Supplemental) is 0x00. If uE parameters 1106, 1206, 1306, 1406 and 3406 are all 0x03, the SE serial parameter (Decode UPC/EAN Supplemental) is 0x02. Otherwise, the SE serial parameter (Decode UPC/EAN Supplemental) is 0xFF.

Note 2: If Parameter 1107 is 00, the SE serial parameter (UPC-A Preamble) is 01. If Parameter 1107 is 03, the SE serial parameter (UPC-A Preamble) is 00. If Parameter 1107 is 04, the SE serial parameter (UPC-A Preamble) is 02. Otherwise, the SE serial parameter (UPC-A Preamble) is 0xFF.

Note 3: If Trioptic Code 39 is set Enable, Code 39 is forced Enable.

Note 4: If Code 39 is set Disable, Trioptic Code 39 is forced Disable.

6-7 UPC-E

Read:

Format

System character "0"	Data digits (6 digits)	Check digits
----------------------	------------------------	--------------

Check digit verification: The check digit verification is optional.

Check digit trans.: By setting Enable, check digit will be transmitted.

Code ID setting: Refer to [Code ID setting](#) of [6-6 UPC-A](#).

Insertion group selection: Refer to [Insertion group selection](#) of [6-6 UPC-A](#).

Supplement digits:

Format

System character "0"	Data digits (6 digits)	Check digit	Supplement digits 2 or 5
----------------------	------------------------	-------------	--------------------------

Truncation/Expansion:

Truncate leading zeros- Refer to [Truncation/Expansion](#) of [6-6 UPC-A](#).

Expand to EAN-13- It extends to 13-digits with "0" digits when the feature is set to be enabled.

Example: Barcode "0123654",

Output: "0012360000057".

Expand to UPC-A- It extends to 12-digits when the feature is set to be enabled.

Example: Barcode "0123654",

Output: "012360000057".

Truncate system character- The system character "0" of UPC-E data can be truncated when this feature is enabled.

Add country code- The country code ("0" for USA) can be added when the feature is enabled.



%SETUP

uE serial				SE serial	
Parameter name	Para. code	Para. option	Para. value	Parameter (Para. No.)	Para. value
Read 1201	0x04 0xB1	Disable Enable	00 01*	UPC-E (0x2)	00 01*
Check digit verification 1202	0x04 0xB2	Disable Enable	00 01*	UPC-E_CheckDigitVerifi- cation (0xF2 0x30)	00 01*
Check digit trans. 1203	0x04 0xB3	Disable Enable	00 01*	UPC-E Transmit CheckDigit (0x29)	00 01*
Code ID setting 1204	0x04 0xB4	00-FF ₁₆ (ASCII)	00-FF ₁₆ <D>*	UPC-E CodeIDSetting (0xF2 0x32)	<A>*



uE serial				SE serial	
Parameter name	Para. code	Para. option	Para. value	Parameter (Para. No.)	Para. value
Insert group selection 1205	0x04 0xB5	00-44	00-44 00*	UPC-E InsertGroup Selection (0xF2 0x33)	00*
Supplement digits 1206	0x04 0xB6	None 2 digits 5 digits 2 or 5 digits	00* 01 02 03	Decode UPC/EAN Supplemental (0x10) ^{Note1}	00* FF ₁₆ FF ₁₆ 02
Truncation/Expansion 1207	0x04 0xB7	None Truncate leading zeros Expand to EAN-13 Expand to UPC-A Truncate system character Add country code	00* 01 02 03 04 05	UPC-E preamble (0x23) Convert UPC-E to A (0x25)	Note2
Reserved 1208	0x04 0xB8			-	-



Note 1: If parameters 1106, 1206, 1306, 1406 and 3406 are all 0x00, the SE serial parameter (Decode UPC/EAN Supplemental) is 0x00. If parameters 1106, 1206, 1306, 1406 and 3406 are all 0x03, the SE serial parameter (Decode UPC/EAN Supplemental) is 0x02. Otherwise, the SE serial parameter (Decode UPC/EAN Supplemental) is 0xFF.

Note 2:

uE serial		SE serial		
Option Bar Code	Para. code	UPC-E preamble (0x23)	Convert UPC-E to A (0x25)	
Truncation/Expansion 1207	0x04 0xB7	00	01	00
		01	FF ₁₆	00
		02	FF ₁₆	00
		03	unchanged	01
		04	00	00
		05	02	00

6-8 UPC-E1

Read:

Format

System character "1"	Data digits (6 digits)	1 check digit
----------------------	------------------------	---------------

Check digit verification: The check digit verification is optional.

Check digit trans.: By setting Enable, check digit will be transmitted.

Code ID setting: Refer to Code ID setting of [6-6 UPC-A](#).

Insertion group selection: Refer to Insertion group selection of [6-6 UPC-A](#).

Supplement digits:

Format

System character "1"	Data digits (6 digits)	Check digit	Supplement digits 2 or 5
----------------------	------------------------	-------------	--------------------------

Truncation/Expansion:

Expand to EAN-13- It extends to 13-digits with "0" digits when the feature is set to be enabled.

Expand to UPC-A- It extends to 12-digits when the feature is set to be enabled.

Truncate system character- The system character "1" of UPC-E1 data can be truncated when the feature is enabled.

Add country code- The country code ("0" for USA) can be added when the feature is enabled.



uE serial				SE serial	
Parameter name	Para. code	Para. option	Para. value	Parameter (Para. No.)	Para. value
Read 3401	0x0D 0x49	Disable Enable	00 01*	UPC-E1(0xC)	00* 01
Check digit verification 3402	0x0D 0x4A	Disable Enable	00 01*	UPC-E1_Check Digit Verification (0xF2 0xBD)	00 01*
Check digit trans. 3403	0x0D 0x4B	Disable Enable	00 01*	UPC-E1_Transmit Check Digit (0x2A)	00 01*
Code ID setting 3404	0x0D 0x4C	00-FF ₁₆ (ASCII)	00-FF ₁₆ <D>*	UPC-E1 Code ID Setting (0xF2 0xBE)	<A>*
Insert group selection 3405	0x0D 0x4D	00-44	00-44 00*	UPC-E1 Insert Group Selection (0xF2 0xBF)	00*



%SETUP

uE serial				SE serial	
Parameter name	Para. code	Para. option	Para. value	Parameter (Para. No.)	Para. value
Supplement digits 3406	0x0D 0x4E	None 2 digits 5 digits 2 or 5 digits	00* 01 02 03	Decode UPC/EAN Supplemental (0x10) ^{Note1}	00* FF ₁₆ FF ₁₆ 02
Truncation/Expansion 3407	0x0D 0x4F	None Reserved Expand to EAN-13 Expand to UPC-A Truncate system character Add country code	00* 01 02 03 04 05	UPC-E1 Preamble (0x24) Convert UPC-E1 to A (0x26)	Note2
Reserved 3408	0x0D 0x50			-	-



%%%%END

Note 1: If parameters 1106, 1206, 1306, 1406 and 3406 are all 0x00, the SE serial parameter (Decode UPC/EAN Supplemental) is 0x00. If parameters 1106, 1206, 1306, 1406 and 3406 are all 0x03, the SE serial parameter (Decode UPC/EAN Supplemental) is 0x02. Otherwise, the SE serial parameter (Decode UPC/EAN Supplemental) is set 0xFF.

Note 2:

Option barode	uE serial para. No.	UPC-E1 Preamble (0x24)	Convert UPC-E1 to A (0x26)
Truncation/Expansion 3407	0x0D 0x4F	00	01
		01	FF ₁₆
		02	FF ₁₆
		03	unchanged
		04	00
		05	02

6-9 EAN-13 (ISBN/ISSN)

Read:

Format

Data digits (12 digits)	1 check digit
-------------------------	---------------

Check digit verification: The check digit verification is optional.

Check digit transmission: By setting Enable, check digit will be transmitted.

Code ID setting: Refer to

Code ID setting

 of [6-6 UPC-A](#).

Insertion group selection: Refer to

Insertion group selection

 of [6-6 UPC-A](#).

Supplement digits:

Format

Data digits (12 digits)	1 check digit	Supplement digits 2 or 5
-------------------------	---------------	--------------------------

ISBN/ISSN conversion: The ISBN (International Standard Book Number) and ISSN (International Standard Serial Number) are two kinds of barcode for books and magazines. The ISBN is 10 digits with leading "978" and the ISSN is 8 digits with leading "977" of the EAN-13 barcode.

Example:

Barcode "9780194315104", Output: "019431510X".

Barcode "9771005180004", Output: "10051805".



uE serial				SE serial	
Parameter name	Para. code	Para. option	Para. value	Parameter (Para. No.)	Para. value
Read 1301	0x05 0x15	Disable Enable	00 01*	EAN-13 (0x03)	00 01*
Check digit verification 1302	0x05 0x16	Disable Enable	00 01*	EAN-13 CheckDigitVerification (0xF2 0x39)	01*
Check digit transmission 1303	0x05 0x17	Disable Enable	00 01*	EAN-13_TransmitCheckDigit (0xF2 0x3A)	00 01*
Code ID setting 1304	0x05 0x18	00-FF ₁₆ (ASCII)	00-FF ₁₆ <A>*	EAN-13 CodeIDSetting (0xF2 0x3B)	<A>*
Insert group selection 1305	0x05 0x19	00-44	00-44 00*	EAN-13 Insert GroupSelection (0xF2 0x3C)	00*
Supplement digits 1306	0x05 0x1A	None 2 digits 5 digits 2 or 5 digits	00* 01 02 03	Decode UPC/EAN Supplemental (0x10) ^{Note1}	00* FF ₁₆ FF ₁₆ 02
ISBN/ISSN conversion 1307	0x05 0x1B	Disable Enable	00* 01	Bookland EAN (0x53)	00* 01
Reserved 1308	0x05 0x1C			-	-
ISBN/ISSN Code ID setting 1309	0x05 0x1D	00-FF ₁₆ (ASCII)	00-FF ₁₆ *	Bookland EAN CodeID Setting (0xF2 0x3D)	<L>*



Note 1: If parameters 1106, 1206, 1306, 1406 and 3406 are all 0x00, the SE serial parameter (Decode UPC/EAN Supplemental) is 0x00. If parameters 1106, 1206, 1306, 1406 and 3406 are all 0x03, the SE serial parameter (Decode UPC/EAN Supplemental) is 0x02. Otherwise, the SE serial parameter (Decode UPC/EAN Supplemental) is set 0xFF.

6-10 EAN-8

Read:

Format

Data digits (7 digits)	1 check digit
------------------------	---------------

Check digit verification: The check digit verification is optional.

Check digit trans.: By setting Enable, check digit will be transmitted.

Code ID setting: Refer to [Code ID setting](#) of [6-6 UPC-A](#).

Insertion group selection: Refer to [Insertion group selection](#) of [6-6 UPC-A](#).

Supplement digits:

Format

Data digits (7 digits)	1 check digit	Supplement Digits 2 or 5
------------------------	---------------	--------------------------

Truncation/Expansion: Refer to [Truncation/Expansion](#) of [6-6 UPC-A](#).



uE serial				SE serial	
Parameter name	Para. code	Para. option	Para. value	Parameter (Para. No.)	Para. value
Read 1401	0x05 0x79	Disable Enable	00 01*	EAN-8 (0x04)	00 01*
Check digit verification 1402	0x05 0x7A	Disable Enable	00 01*	EAN-8 CheckDigitVerification (0xF2 0x40)	00 01*
Check digit trans. 1403	0x05 0x7B	Disable Enable	00 01*	EAN-8 TransmitCheckDigit (0xF2 0x41)	00 01*
Code ID setting 1404	0x05 0x7C	00-FF ₁₆ (ASCII)	00-FF ₁₆ <C>*	EAN-8 CodeIDSetting (0xF2 0x42)	<A>
Insert group selection 1405	0x05 0x7D	00-44 00*	00-44 00*	EAN-8 InsertGroupSelection (0xF2 0x43)	00-44 00*
Supplement digits 1406	0x05 0x7E	None 2 digits 5 digits 2 or 5 digits	00* 01 02 03	Decode UPC/EAN Supplemental (0x10) ^{Note1}	00* FF ₁₆ FF ₁₆ 02
Truncation/Expansion 1407	0x05 0x7F	None Truncate leading zero Expand to EAN-13	00* 01 02	EAN-8 Zero Extend (0x27) ^{Note2}	00* FF ₁₆ 01
Reserved 1408	0x05 0x80			-	-



Note 1: If parameters 1106, 1206, 1306, 1406 and 3406 are all 0x00, the SE serial parameter (Decode UPC/EAN Supplemental) is 0x00. If parameters 1106, 1206, 1306, 1406 and 3406 are all 0x03, the SE serial parameter (Decode UPC/EAN Supplemental) is 0x02. Otherwise, the SE serial parameter (Decode UPC/EAN Supplemental) is set 0xFF.

Note 2: If parameter 1407 is 0x00, the SE serial parameter (EAN-8 Zero Extend) is 0x00. If parameter 1407 is 0x02, the SE serial parameter (EAN-8 Zero Extend) is 0x01. Otherwise the SE serial parameter (EAN-8 Zero Extend) is 0xFF.

6-11 Code 39 (Code 32, Trioptic Code 39)

Read:

Format

*	Data digits (variable)	1 check digit (optional)	*
---	------------------------	--------------------------	---

Check digit verification: The check digit is optional and made as the sum module 43 of the numerical value of the data digits.

Check digit transmission: By setting Enable, check digit will be transmitted.

Max./Min. code length: Each type of barcode has own max./min. code length. If both setting of max./min. code length are "00"s, the setting of global max./min. code length is effective. The length is defined as to the actual barcode data length to be sent. Label with length exceeds these limits will be rejected. Make sure that the minimum length setting is no greater than the maximum length setting, or otherwise all the labels of the type of barcode will not be readable. In particular, you can see the same value for both minimum and maximum reading length to force the fixed length barcode decoded.

Code ID setting: Refer to [Code ID setting](#) of [6-6 UPC-A](#).

Insertion group selection: Refer to [Insertion group selection](#) of [6-6 UPC-A](#).

Start/End transmission: The start and end characters of Code 39 are "*"s. By setting Enable, all data digits including two "*"s can be transmitted.

"*" as data character: By setting Enable, "*" can be recognized as data character.

Convert Code 39 to Code 32: Code 32 is a variant of Code 39 used by the Italian pharmaceutical industry. Note that Code 39 must be enabled in order for this parameter to function.

Format of Code 32

"A" (optional)	Data digits (8 digits)	1 check digit
----------------	------------------------	---------------

Code 32 Prefix "A" transmission: By setting Enable, the prefix character "A" can be added to all Code 32 barcodes.

Trioptic Code 39 read: Trioptic Code 39 is a variant of Code 39 used in the marking of magnetic tapes and computer cartridges. Trioptic Code 39 barcodes always contain six characters.

Format

\$	Data digits (6 digits)	\$
----	------------------------	----

Trioptic Code 39 Start/End transmission: The start and end characters of Trioptic Code 39 are "\$"s. You can transmit all data digits including two "\$"s.



uE serial				SE serial	
Parameter name	Para. code	Para. option	Para. value	Parameter (Para. No.)	Para. value
Read 1501	0x05 0xDD	Disable Enable	00 01*	Code 39 (0x00)	00 01*
Check digit verification 1502	0x05 0xDE	Disable Enable	00* 01	Code 39 Check Digit (0x30)	00* 01



%SETUP

uE serial				SE serial	
Parameter name	Para. code	Para. option	Para. value	Parameter (Para. No.)	Para. value
Check digit transmission 1503	0x05 0xDF	Disable Enable	00* 01	Transmit Code 39 Check Digit (0x2B)	00* 01
Max. code length 1504	0x05 0xE0	00-99	00-99 99*	Set Length(s) for Code 39 L1: (0x12) L2: (0x13) ^{Note 1}	02* 55*
Min. code length 1505	0x05 0xE1	00-99	00-99 01*		
Code ID setting 1506	0x05 0xE2	00-FF ₁₆ (ASCII)	00-FF ₁₆ <M>*	Code39 CodeIDSetting (0xF2 0x49)	*
Insert group selection 1507	0x05 0xE3	00-44	00-44 00*	InsertGroupSelection (0xF2 0x4A)	00-44 00*
Format 1508	0x05 0xE4	Standard Full ASCII	00* 01	Code 39 Full ASCII Conversion (0x11)	00* 01
Start/End transmission 1509	0x05 0xE5	Disable Enable	00* 01	Code39 StartEndTransmission (0xF2 0x4B)	00* 01
“*” as data character 1510	0x05 0xE6	Disable Enable	00* 01	Code39StartAsDataCharacter (0xF2 0x4C)	00* 01
Convert Code 39 to Code 32 1511	0x05 0xE7	Disable Enable	00* 01	Convert Code 39 to Code 32 (0x56)	00* 01
Code 32 Prefix “A” transmission 1512	0x05 0xE8	Disable Enable	00* 01	Code 32 Prefix (0xE7)	00* 01
Trioptic Code 39 read 1513	0x05 0xE9	Disable Enable	00 01*	Trioptic Code 39 (0x0D) ^{Note2}	00* 01
Trioptic Code 39 Start/End trans. 1514	0x05 0xEA	Disable Enable	00* 01	TriopticCode39StartEndTransmission (0xF2 0x4D)	00* 01



%%%END

Note 1: If parameter 1504 is equal to parameter 1505, the SE serial parameters are L1 = parameter 1504 and L2=0. Otherwise, L1=Parameter 1505 and L2= Parameter 1504.

Note 2: If parameter 1501 is 0x00, the SE serial parameter (Trioptic Code 39) is forced to be 0x00. Otherwise the SE serial parameter (Trioptic Code 39) is always equal to parameter 1513.

6-12 Interleaved 2 of 5

Read:

Format

Data digits (Variable)	1 check digit (optional)
------------------------	--------------------------

Check digit verification: The check digit verification is optional. There are two optional check digit algorithms: the Uniform Type of barcode Specification (USS) and the Optical Product Code Council (OPCC).

Check digit transmission: By setting Enable, check digit will be transmitted.

Max./Min. code length: Refer to

Max./Min. code length

 of [6-11 Code 39](#).

Code ID setting: Refer to

Code ID setting

 of [6-6 UPC-A](#).

Insertion group selection: Refer to

Insertion group selection

 of [6-6 UPC-A](#).



uE serial				SE serial	
Parameter name	Para. code	Para. option	Para. value	Parameter (Para. No.)	Para. value
Read 1601	0x06 0x41	Disable Enable	00 01*	Interleaved2of5 (0x06)	00 01*
Check digit verification 1602	0x06 0x42	Disable USS OPCC	00* 01 02	I2of5 Check Digit Verification (0x31)	00* 01 02
Check digit transmission 1603	0x06 0x43	Disable Enable	00* 01	Transmit I2of5 Check Digit (0x2C)	00* 01
Max. code length 1604	0x06 0x44	00-99	00-99 99*	Set Length(s) for I2 of 5 L1: (0x16) L2: (0x17) ^{Note 1}	14* 14*
Min. code length 1605	0x06 0x45	00-99	00-99 06*		
Code ID setting 1606	0x06 0x46	00-FF ₁₆ (ASCII)	00-FF ₁₆ < >*	I2of5 CodeID Setting (0xF2 0x50)	<F>*
Insert group selection 1607	0x06 0x47	00-44	00-44 00*	I2of5_InsertGroupSelection (0xF2 0x51)	00-44 00*
Reserved 1608	0x06 0x48			-	-



Note 1: If parameter 1604 is equal to parameter 1605, the SE serial parameters are L1 = parameter 1604 and L2=0. Otherwise, L1=Parameter 1605 and L2= Parameter 1604.

6-13 Industrial 2 of 5

Read:

Format

Data digits (variable)

Max./Min. code length: Refer to Max./Min. code length of 6-11 Code 39.

Code ID setting: Refer to Code ID setting of 6-6 UPC-A.

Insertion group selection: Refer to Insertion group selection of 6-6 UPC-A.



uE serial				SE serial	
Parameter name	Para. code	Para. option	Para. value	Parameter (Para. No.)	Para. value
Read 1701	0x06 0xA5	Disable Enable	00* 01	Industrial2of5 (0x05)	00* 01
Max. code length 1702	0x06 0xA6	00-99	00-99 99*	Set Length(s) for Industrial 2 of 5 L1: (0x14) L2: (0x15) ^{Note 1}	12* 12*
Min. code length 1703	0x06 0xA7	00-99	00-99 04*		
Code ID setting 1704	0x06 0xA8	00-FF ₁₆ (ASCII)	00-FF ₁₆ <H>*	Industrial2of5_CodeIDSettin g (0xF2 0x5B)	<G>*
Insert group selection 1705	0x06 0xA9	00-44	00-44 00*	InsertGroupSelection (0xF2 0x5C)	00-44 00*
Reserved 1706	0x06 0xAA			-	-



Note 1: If parameter 1704 is equal to parameter 1705, the SE serial parameters are L1 = parameter 1704 and L2=0. Otherwise, L1=Parameter 1705 and L2= Parameter 1704.

6-14 Matrix 2 of 5

Read:

Format

Data digits (variable)	1 check digit (optional)
------------------------	--------------------------

Check digit verification: The check digit verification is optional.

Check digit transmission: By setting Enable, check digit will be transmitted.

Max./Min. code length: Refer to **Max./Min. code length** of [6-11 Code 39](#).

Code ID setting: Refer to **Code ID setting** of [6-6 UPC-A](#).

Insertion group selection: Refer to **Insertion group selection** of [6-6 UPC-A](#).



uE serial				SE serial	
Parameter name	Para. code	Para. option	Para. value	Parameter (Para. No.)	Para. value
Read 1801	0x07 0x09	Disable Enable	00 01*	Matrix2of5 (0xF2 0x60)	00 01*
Check digit verification 1802	0x07 0x0A	Disable Enable	00* 01	Matrix2of5_CheckDigitVerificati on (0xF2 0x61)	00* 01
Check digit transmission 1803	0x07 0x0B	Disable Enable	00* 01	Matrix2of5 TransmitCheckDigit (0xF2 0x62)	00* 01
Max. code length 1804	0x07 0x0C	00-99	00-99 99*	Set Length(s) for Matrix 2of5 L1: (0xF2 0x63) L2: (0xF2 0x64) ^{Note 1}	00*
Min. code length 1805	0x07 0x0D	00-99	00-99 06*		00*
Code ID setting 1806	0x07 0x0E	00-FF ₁₆ (ASCII)	00-FF ₁₆ <X>*	Matrix2Of5_CodeIDSetting (0xF2 0x65)	<X>*
Insert group selection 1807	0x07 0x0F	00-44	00-44 00*	Matrix2of5_InsertGroupSelecti on (0xF2 0x66)	00-44 00*
Reserved 1808	0x07 0x10			-	-



Note 1: If parameter 1804 is equal to parameter 1805, the SE serial parameters are L1 = parameter 1804 and L2=0. Otherwise, L1=Parameter 1805 and L2= Parameter 1804.

6-15 Codabar

Read:

Format

Start character	Data digits (variable)	Check digit (optional)	End character
-----------------	------------------------	------------------------	---------------

Check digit verification: The check digit verification is optional.

Check digit transmission: By setting Enable, check digit will be transmitted.

Max./Min. code length: Refer to [Max./Min. code length](#) of [6-11 Code 39](#).

Code ID setting: Refer to [Code ID setting](#) of [6-6 UPC-A](#).

Insertion group selection: Refer to [Insertion group selection](#) of [6-6 UPC-A](#).

Start/End type: Codabar has four pairs of Start/End pattern; you may select one pair to match your application.

Start/End transmission: Refer to [Start/End transmission](#) of Code 39.

Start/End character equality: By setting Enable, the start and end characters of a Codabar barcode must be the same.



%SETUP

uE serial				SE serial	
Parameter name	Para. code	Para. option	Para. value	Parameter (Para. No.)	Para. value
Read 1901	0x07 0x6D	Disable Enable	00 01*	Codabar (0x07)	00* 01
Check digit verification 1902	0x07 0x6E	Disable Enable	00* 01	CodeBar_CheckDigit Verification (0xF2 0x68)	00* 01
Check digit transmission 1903	0x07 0x6F	Disable Enable	00* 01	CodeBar_Transmit CheckDigit (0xF2 0x69)	00* 01
Max. code length 1904	0x07 0x70	00-99	00-99 99*	Set Lengths for Codabar L1: (0x18) L2: (0x19) ^{Note1}	05* 55*
Min. code length 1905	0x07 0x71	00-99	00-99 04*		
Code ID setting 1906	0x07 0x72	00-FF ₁₆ (ASCII)	00-FF ₁ 6 <N>*	CodeBar_CodeIDSetting (0xF2 0x6A)	<C> *
Insert group selection 1907	0x07 0x73	00-44	00-44 00*	CodeBar_InsertGroup Selection (0xF2 0x6B)	00*
Start/End type 1908	0x07 0x74	ABCD/ABCD abcd/abcd ABCD/TN*E abcd/tn*e	00* 01 02 03	CodeBar_StartEndTyp (0xF2 0x6C)	00* 01 02 03
Start/End transmission 1909	0x07 0x75	Disable Enable	00* 01	NOTIS Editing (0x37) ^{Note2}	01 00*
Start/End character equality 1910	0x07 0x76	Disable Enable	00* 01	CodeBar_StartEnd CharacterEquality (0xF2 0x6D)	00* 01



%%%END

Note 1: If parameter 1904 is equal to parameter 1905, the SE serial parameters are L1 = parameter 1904 and L2=0. Otherwise, L1=Parameter 1905 and L2= Parameter 1904.

Note2: If parameter 1909 is 0x00, the SE serial parameter (NOTIS Editing) is 0x01.

6-16 Code 128

Read:

Format

Data digits (variable)	1 check digit (optional)
------------------------	--------------------------

Check digit verification: The check digit verification is optional.

Check digit transmission: By setting Enable, check digit will be transmitted.

Max./Min. code length: Refer to [Max./Min. code length](#) of [6-11 Code 39](#).

Code ID setting: Refer to [Code ID setting](#) of [6-6 UPC-A](#).

Insertion group selection: Refer to [Insertion group selection](#) of [6-6 UPC-A](#).

Truncate leading zeros: The leading “0” digits of Code 128 barcode characters can be truncated when the feature is enabled.



uE serial				SE serial	
Parameter name	Para. code	Para. option	Para. value	Parameter (Para. No.)	Para. value
Read 2001	0x07 0xD1	Disable Enable	00 01*	Code 128 (0x08)	00 01*
Check digit verification 2002	0x07 0xD2	Disable Enable	00 01*	Code 128_CheckDigitVerification (0xF2 0x70)	00 01*
Check digit transmission 2003	0x07 0xD3	Disable Enable	00* 01	Code 128_Transmit CheckDigit (0xF2 0x71)	00* 01
Max. code length 2004	0x07 0xD4	00-99	00-99 99*	Set Lengths for Code 128 L1: (0xF2 0x72) L2: (0xF2 0x73) ^{Note1}	00* 00*
Min. code length 2005	0x07 0xD5	00-99	00-99 01*		
Code ID setting 2006	0x07 0xD6	00-FF ₁₆ (ASCII)	00-FF ₁₆ <K>*	Code 128_CodeIDSetting (0xF2 0x74)	<D> *
Insert group selection 2007	0x07 0xD7	00-44	00-44 00*	Code128_InsertGroupSelection (0xF2 0x75)	00-44 00*
Truncate leading zeros 2008	0x07 0xD8	Disable All leading "0"s Only the first "0"	00* 01 02	Code 128_TruncateLeadingZeros (0xF2 0x76)	00* 01 02



Note 1: If parameter 2004 is equal to parameter 2005, the SE serial parameters are L1 = parameter 2004 and L2=0. Otherwise, L1=Parameter 2005 and L2= Parameter 2004.

6-17 UCC/EAN 128

Read:

Format

Data digits (variable)	1 check digit (optional)
------------------------	--------------------------

Check digit verification: The check digit is made as the sum module 103 of all data digits.

Check digit transmission: By setting Enable, check digit will be transmitted.

Max. /Min. code length: Refer to **Max./Min. code length** of [6-11 Code 39](#).

Code ID setting: Refer to **Code ID setting** of [6-6 UPC-A](#).

Insertion group selection: Refer to **Insertion group selection** of [6-6 UPC-A](#).

Truncate leading zeros: Refer to **Truncate leading zeros** of [6-16 Code 128](#).



uE serial				SE serial	
Parameter name	Para. code	Para. option	Para. value	Parameter (Para. No.)	Para. value
Read 2501	0x09 0xC5	Disable Enable	00 01*	UCC/EAN-128 (0x0E)	00 01*
Check digit verification 2502	0x09 0xC6	Disable Enable	00 01*	UCCEAN128_CheckDigitVerificati on (0xF2 0x98)	00 01*
Check digit transmission 2503	0x09 0xC7	Disable Enable	00* 01	UCCEAN128_TransmitCheckDigit (0xF2 0x99)	00* 01
Max. code length 2504	0x09 0xC8	00-99	00-99 99*	Set Lengths for UCCEAN 128 L1: (0xF2 0x9A) L2: (0xF2 0x9B) ^{Note1}	00* 00*
Min. code length 2505	0x09 0xC9	00-99	00-99 01*		
Code ID setting 2506	0x09 0xCA	00-FF ₁₆ (ASCII)	00-FF ₁₆ <K>*	UCCEAN128_CodeIDSetting (0xF2 0x9C)	<K>*
Insert group selection 2507	0x09 0xCB	00-44	00-44 00*	UCCEAN128_InsertGroupSelectio n (0xF2 0x9D)	00-44 00*
Truncate leading zeros 2508	0x09 0xCC	Disable All leading "0"s Only the first "0"	00* 01 02	UCCEAN128_TruncateLeadingZe ros (0xF2 0x9E)	00* 01 02



Note 1: If parameter 2504 is equal to parameter 2505, the SE serial parameters are L1 = parameter 2504 and L2=0. Otherwise, L1=Parameter 2505 and L2= Parameter 2504.

6-18 ISBT 128

Read:

Format

"=" or "&"	Data digits (variable)	1 check digit (optional)
------------	------------------------	--------------------------

Check digit verification: The check digit verification is optional.

Check digit transmission: By setting Enable, check digit will be transmitted.

Max./Min. code length: Refer to Max./Min. code length of [6-11 Code 39](#).

Code ID setting: Refer to Code ID setting of [6-6 UPC-A](#).

Insertion group selection: Refer to Insertion group selection of [6-6 UPC-A](#).



uE serial				SE serial	
Parameter name	Para. code	Para. option	Para. value	Parameter (Para. No.)	Para. value
Read 3301	0x0C 0xE5	Disable Enable	00 01*	ISBT 128 (0x54)	00 01*
Check digit verification 3302	0x0C 0xE6	Disable Enable	00 01*	ISBT 128_CheckDigitVerification (0xF2 0xB6)	00 01*
Check digit transmission 3303	0x0C 0xE7	Disable Enable	00* 01	ISBT 128_TransmitCheckDigit (0xF2 0xB7)	00* 01
Max. code length 3304	0x0C 0xE8	00-99	00-99 99*	Set Lengths for ISBT 128 L1: (0xF2 0xB8) L2: (0xF2 0xB9) ^{Note1}	00* 00*
Min. code length 3305	0x0C 0xE9	00-99	00-99 01*		
Code ID setting 3306	0x0C 0xEA	00-FF ₁₆ (ASCII)	00-FF ₁₆ <K>*	ISBT 128_CodeIDSetting (0xF2 0xBA)	<D>*
Insert group selection 3307	0x0C 0xEB	00-44	00-44 00*	UCCEAN128_InsertGroupSelectio n (0xF2 0xBB)	00-44 00*



Note 1: If parameter 3304 is equal to parameter 3305, the SE serial parameters are L1 = parameter 3304 and L2=0. Otherwise, L1=Parameter 3305 and L2= Parameter 3304.

6-19 Code 93

Read:

Format

Data digits (variable)	2 check digits (optional)
------------------------	---------------------------

Check digit verification: The check digit verification is optional.

Check digit transmission: By setting Enable, check digit will be transmitted.

Max./Min. code length: Refer to Max./Min. code length of [6-11 Code 39](#).

Code ID setting: Refer to Code ID setting of [6-6 UPC-A](#).

Insertion group selection: Refer to Insertion group selection of [6-6 UPC-A](#).



uE serial				SE serial	
Parameter name	Para. code	Para. option	Para. value	Parameter (Para. No.)	Para. value
Read 2101	0x08 0x35	Disable Enable	00 01*	Code 93 (0x09)	00* 01
Check digit verification 2102	0x08 0x36	Disable Enable	00 01*	Code93_CheckDigitVerification (0xF2 0x79)	00 01*
Check digit transmission 2103	0x08 0x37	Disable Enable	00* 01	Code93_TransmitCheckDigit (0xF2 0x7A)	00* 01
Max. code length 2104	0x08 0x38	00-99	00-99 99*	Set Length(s) for Code 93 L1: (0x1A) L2: (0X1B) <small>Note1</small>	04* 55*
Min. code length 2105	0x08 0x39	00-99	00-99 01*		
Code ID setting 2106	0x08 0x3A	00-FF ₁₆ (ASCII)	00-FF ₁₆ <L>*	Code93_CodeIDSetting (0xF2 0x7B)	<E>*
Insert group selection 2107	0x08 0x3B	00-44	00-44 00*	Code93_InsertGroupSelection (0xF2 0x7C)	00-44 00*
Reserved 2108	0x08 0x3C			-	-



Note 1: If parameter 2104 is equal to parameter 2105, the SE serial parameters are L1 = parameter 2104 and L2=0. Otherwise, L1=Parameter 2105 and L2= Parameter 2104.

6-20 Code 11

Read:

Format

Data digits (variable)	Check digit 1 (optional)	Check digit 2 (optional)
------------------------	--------------------------	--------------------------

Check digit verification: The check digit is presented as the sum module 11 of all data digits.

Check digit transmission: By setting Enable, check digit 1 and check digit 2 will be transmitted upon your selected check digit verification method.

Max./Min. code length: Refer to [Max./Min. code length](#) of [6-11 Code 39](#).

Code ID setting: Refer to [Code ID setting](#) of [6-6 UPC-A](#).

Insertion group selection: Refer to [Insertion group selection](#) of [6-6 UPC-A](#).



uE serial				SE serial	
Parameter name	Para. code	Para. option	Para. value	Parameter (Para. No.)	Para. value
Read 2201	0x08 0x99	Disable Enable	00* 01	Code 11 (0x0A)	00* 01
Check digit verification 2202	0x08 0x9A	Disable One digit Two digit	00 01* 02	Code 11 Check Digit Verification (0x34)	00* 01 02
Check digit transmission 2203	0x08 0x9B	Disable Enable	00* 01	Transmit Code 11 Check Digit (0x2F)	00* 01
Max. code length 2204	0x08 0x9C	00-99	00-99 99*	Set Lengths for Code 11 L1: (0x1C) L2: (0x1D) ^{Note1}	04* 55*
Min. code length 2205	0x08 0x9D	00-99	00-99 04*		
Code ID setting 2206	0x08 0x9E	00-FF ₁₆ (ASCII)	00-FF ₁₆ <V>*	Code11_CodeIDSetting (0xF2 0x80)	<H>*
Insert group selection 2207	0x08 0x9F	00-44	00-44 00*	Code11_InsertGroupSelection (0xF2 0x81)	00-44 00*
Reserved 2208	0x08 0xA0			-	-



Note 1: If parameter 2204 is equal to parameter 2205, the SE serial parameters are L1 = parameter 2204 and L2=0. Otherwise, L1=Parameter 2205 and L2= Parameter 2204.

6-21 MSI/Plessey

Read:

Format

Data digits (variable)	Check digit 1 (optional)	Check digit 2 (optional)
------------------------	--------------------------	--------------------------

Check digit verification: The MSI/Plessey has one or two optional check digits. There are three methods of verifying check digits, i.e. Mod 10, Mod 10/10 and Mod 10/11. The check digit 1 and check digit 2 will be calculated as the sum module 10 or 11 of the data digits.

Check digit transmission: By setting Enable, check digit 1 and check digit 2 will be transmitted upon your selected check digit verification method.

Max./Min. code length: Refer to [Max./Min. code length](#) of [6-11 Code 39](#).

Code ID setting: Refer to [Code ID setting](#) of [6-6 UPC-A](#).

Insertion group selection: Refer to [Insertion group selection](#) of [6-6 UPC-A](#).



uE serial				SE serial	
Parameter name	Para. code	Para. option	Para. value	Parameter (Para. No.)	Para. value
Read 2301	0x08 0xFD	Disable Enable	00* 01	MSI (0x0B)	00* 01
Check digit verification 2302	0x08 0xFE	Disable 1 digit (Mod 10) 2 digits (Mod 10/10) 2 digits (Mod 10/11)	00* 01 02 03	MSI_Check_Digit (0x32) MSI_Check_Digit_Algorithm (0x33) ^{Note1}	0x00* 0x01*
Check digit transmission 2303	0x08 0xFF	Disable Enable	00* 01	Transmit MSI Check Digit (0x2E)	00* 01
Max. code length 2304	0x09 0x00	00-99	00-99 99*	Set Lengths for MSI L1: (0x1E) L2: (0x1F) ^{Note2}	06* 37*
Min. code length 2305	0x09 0x01	00-99	00-99 04*		
Code ID setting 2306	0x09 0x02	00-FF ₁₆ (ASCII)	00-FF ₁₆ <O>*	MSI_CodeID (0xF2 0x88)	<J>*
Insert group selection 2307	0x09 0x03	00-44	00-44 00*	MSI_InsertGroupSelection (0xF2 0x89)	00-44 00*
Reserved 2308	0x09 0x04			-	-



Note 1:

If parameter 2302 is 0x01, the SE serial parameter MSI_Check_Digit (0x32) is 0x00.

If parameter 2302 is 0x03, the SE serial parameter MSI_Check_Digit (0x32) is 0x01 and MSI_Check_Digit_Algorithm (0x33) is 0x00.

If parameter 2302 is 0x02, the SE serial parameter MSI_Check_Digit (0x32) is 0x01 and MSI_Check_Digit_Algorithm (0x33) is 0x01.

Otherwise, the SE serial parameter MSI_Check_Digit (0x32) is 0xFF.

Note 2:

If parameter 2304 is equal to parameter 2305, the SE serial parameters are L1 = parameter 2304 and L2=0.

Otherwise, L1=Parameter 2305 and L2= Parameter 2304.

6-22 UK/Plessey

Read:

Format

Data digits (variable)	2 check digits (optional)
------------------------	---------------------------

Check digit verification: The UK/Plessey has two optional check digits.

Check digit transmission: By setting Enable, check digit will be transmitted.

Max./Min. code length: Refer to **Max./Min. code length** of [6-11 Code 39](#).

Code ID setting: Refer to **Code ID setting** of [6-6 UPC-A](#).

Insertion group selection: Refer to **Insertion group selection** of [6-6 UPC-A](#).



uE serial				SE serial	
Parameter name	Para. code	Para. option	Para. value	Parameter (Para. No.)	Para. value
Read 2401	0x09 0x61	Disable Enable	00 01*	UK_Plessey (0xF2 0x90)	00 01*
Check digit verification 2402	0x09 0x62	Disable Enable	00 01*	UK_PlesseyCheckDigitVerification (0xF2 0x91)	00 01*
Check digit transmission 2403	0x09 0x63	Disable Enable	00* 01	UK_PlesseyTransmitCheckDigit (0xF2 0x92)	00* 01
Max. code length 2404	0x09 0x64	00-99	00-99 99*	Set Lengths for UK_Plessey L1: (0xF2 0x93) L2: (0xF2 0x94) <small>Note1</small>	00*
Min. code length 2405	0x09 0x65	00-99	00-99 01*		00*
Code ID setting 2406	0x09 0x66	00-FF ₁₆ (ASCII)	00-FF ₁₆ <U>*	UK_Plessey_CodeIDSetting (0xF2 0x95)	<U>*
Insert group selection 2407	0x09 0x67	00-44	00-44 00*	UK_Plessey_InsertGroupSelection (0xF2 0x96)	00-44 00*
Reserved 2408	0x09 0x68			-	-



Note 1: If parameter 2404 is equal to parameter 2405, the SE serial parameters are L1 = parameter 2404 and L2=0. Otherwise, L1=Parameter 2405 and L2= Parameter 2404.

6-23 China Post

Read:

Format

11 Data digits

Code ID setting: Refer to [Code ID setting](#) of [6-6 UPC-A](#).

Insertion group selection: Refer to [Insertion group selection](#) of [6-6 UPC-A](#).



uE serial				SE serial	
Parameter name	Para. code	Para. option	Para. value	Parameter (Para. No.)	Para. value
Read 2601	0x0A 0x29	Disable Enable	00 01*	Chinese 2 of 5 (0xF0 0x98)	00* 01
Reserved 2602	0x0A 0x2A			-	-
Reserved 2603	0x0A 0x2B			-	-
Reserved 2604	0x0A 0x2C			-	-
Reserved 2605	0x0A 0x2D			-	-
Code ID setting 2606	0x0A 0x2E	00-FF ₁₆ (ASCII)	00-FF ₁₆ <T>*	ChinaPost_CodeID (0xF2 0xA4)	<T>*
Insert group selection 2607	0x0A 0x2F	00-44	00-44 00*	ChinaPost_InsertGroupSelection (0xF2 0xA5)	00-44 00*
Reserved 2608	0x0A 0x30			-	-



6-24 GS1 DataBar (GS1 DataBar Truncated)

GS1 DataBar Truncated is structured and encoded as the same as the standard GS1 DataBar format, except its height is reduced to a 13 modules minimum; while GS1 DataBar should have a height greater than or equal to 33 modules.

Read:

Format

16 Data digits

Code ID setting: Refer to Code ID setting of 6-6 UPC-A.

Insertion group selection: Refer to Insertion group selection of 6-6 UPC-A.

Conversion:

UCC/EAN 128- Refer to Code ID transmission of 6-29 String transmission, “[C]m” will be identified as AIM ID.

UPC-A or EAN-13- Barcode beginning with a single zero as the first digit has the leading “010” stripped and the barcode reported as EAN-13. Barcode beginning with two to five zeros has the leading “0100” stripped and the barcode reported as UPC-A.



uE serial				SE serial	
Parameter name	Para. code	Para. option	Para. value	Parameter (Para. No.)	Para. value
Read 2701	0x0A 0x8D	Disable Enable	00 01*	RSS-14 (0xF0 0x52)	00* 01
Code ID setting 2702	0x0A 0x8E	00-FF ₁₆ (ASCII)	00-FF ₁₆ <R>*	RSS-14_CodeIDSetting (0xF2 0xA8)	<R>*
Insert group selection 2703	0x0A 0x8F	00-44	00-44 00*	RSS-14_InsertGroupSelection (0xF2 0xA9)	00-44 00*
Conversion 2704	0x0A 0x90	None UCC/EAN 128 UPC-A or EAN-13	00* 01 02	Convert RSS to UPC/EAN (0xF0 0X8D) ^{Note1}	00* FF ₁₆ 01
Reserved 2705	0x0A 0x91			-	-
%%%END					

Note 1: If parameters 2704 and 2804 are both 0x00, the SE serial parameter Convert RSS to UPC/EAN is 0x00. If parameters 2704 and 2804 are both 0x02, the SE serial parameter Convert RSS to UPC/EAN is 0x01. Otherwise the SE serial parameter Convert RSS to UPC/EAN is 0xFF.

6-25 GS1 DataBar Limited

Read:

Format

16 Data digits

Code ID setting: Refer to [Code ID setting](#) of [6-6 UPC-A](#).

Insertion group selection: Refer to [Insertion group selection](#) of [6-6 UPC-A](#).

Conversion: Refer to [Conversion](#) of [6-24 GS1 DataBar \(GS1 DataBar Truncated\)](#).



uE serial				SE serial	
Parameter name	Para. code	Para. option	Para. value	Parameter (Para. No.)	Para. value
Read 2801	0x0A 0xF1	Disable Enable	00 01*	RSS-Limited (0xF0 0x53)	00* 01
Code ID setting 2802	0x0A 0xF2	00-FF ₁₆ (ASCII)	00-FF ₁₆ <R>*	RSS-Limited_CodeIDSetting (0xF2 0xAB)	<R>*
Insert group selection 2803	0x0A 0xF3	00-44	00-44 00*	RSS-Limited_InsertGroupSelectio n (0xF2 0xAC)	00
Conversion 2804	0x0A 0xF4	None UCC/EAN 128 UPC-A or EAN-13	00* 01 02	Convert RSS to UPC/EAN (0xF0 0X8D) <small>Note1</small>	00* FF ₁₆ 01
Reserved 2805	0x0A 0xF5			-	-



Note 1: If parameters 2704 and 2804 are both 0x00, the SE serial parameter Convert RSS to UPC/EAN is 0x00. If parameters 2704 and 2804 are both 0x02, the SE serial parameter Convert RSS to UPC/EAN is 0x01. Otherwise the SE serial parameter Convert RSS to UPC/EAN is 0xFF.

6-26 GS1 DataBar Expanded

Read:

Format

Data characters (variable)

Code ID setting: Refer to Code ID setting of [6-6 UPC-A](#).

Insertion group selection: Refer to Insertion group selection of [6-6 UPC-A](#).

Conversion:

UCC/EAN 128- Refer to Code ID transmission of [6-29 String transmission](#), “[J]Cm” will be identified as AIM ID.



uE serial				SE serial	
Parameter name	Para. code	Para. option	Para. value	Parameter (Para. No.)	Para. value
Read 2901	0x0B 0x55	Disable Enable	00 01*	RSS-Expanded (0xF0 0x54)	00* 01
Max. code length 2902	0x0B 0x56	00-99	00-99 99*	Set Lengths for RSS-Expanded L1: (0xF2 0xB0) L2: (0xF2 0xB1) ^{Note1}	00* 00*
Min. code length 2903	0x0B 0x57	00-99	00-99 01*		
Code ID setting 2904	0x0B 0x58	00-FF ₁₆ (ASCII)	00-FF ₁₆ <R >*	RSS-Expanded_CodeIDSetting (0xF2 0xB2)	<R >*
Insert group selection 2905	0x0B 0x59	00-44	00-44 00*	RSS-Expanded_InsertGroupSelec tion (0xF2 0xB3)	00-44 00*
Conversion 2906	0x0B 0x5A	None UCC/EAN 128	00* 01	RSS-Expanded_Conversion (0xF2 0xB4)	00* 01
Reserved 2907	0x0B 0x5B			-	-



Note 1: If parameter 2902 is equal to parameter 2903, the SE serial parameters are L1 = parameter 2902 and L2=0. Otherwise, L1=Parameter 2903 and L2= Parameter 2902.

6-27 G1-G4 & FN1 substitution string setting

Format of barcode data transmission:

Prefix	Code name	Preamble	Code ID	Code length	Code data	Code ID	Postamble	Suffix
--------	-----------	----------	---------	-------------	-----------	---------	-----------	--------

Suffix string setting: The <enter> key is represented in different ASCII when it is applied by different OS. For a Windows/DOS OS, <enter> is represented as <CR><LF> (0x0D 0x0A); for an Apple MAC OS, <enter> is represented as <CR> (0x0D); for a Linux/Unix OS, <enter> is represented as <LF> (0x0A).

Prefix/Suffix/Preamble/Postamble string setting:

They are appended to the data automatically when a barcode is decoded.

Example: Add a type of barcode of “\$” as a prefix for all types of barcode.

Steps:

- 1) Scan **SETUP** and **Prefix string setting** barcode.
- 2) Use the ASCII table to find the value of \$→24.
- 3) Scan barcode **2** and barcode **4** in [14 Configuration alphanumeric entry barcode \(as Para. value\)](#).
- 4) Scan **END** barcode.
- 5) Refer to [6-29 String transmission](#), set **Prefix transmission** to be Enable.

Scanning steps: Scan the following barcodes in order.

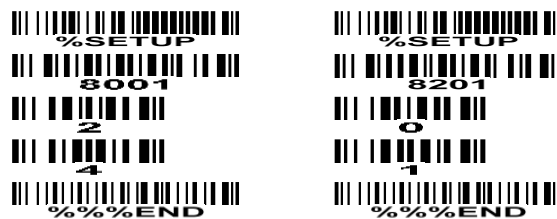

Insert G1/G2/G3/G4 string setting: The engine offers 4 positions and 4 character strings to insert among the barcode data string.

Example: Set G1 string to be “AB”.

Original code data	“1 2 3 4 5 6”
Output code data	“1 2 A B 3 4 5 6”

Steps:

- 1) Scan **SETUP** and **Insert G1 string setting** barcode.
- 2) Use the ASCII table to find the value of A→41, B→42.
- 3) Scan **4, 1** and **4, 2** in [14 Configuration alphanumeric entry barcode \(as Para. value\)](#).
- 4) Scan **END** barcode.
- 5) Refer to [6-28 G1-G4 string position & Code ID position](#).
- 6) Refer to [6-4 Trigger mode & some global settings](#).



Testing barcode:



FN1 substitution string setting: The FN1 character (0x1D) in an UCC/EAN128 barcode, or a Code 128 barcode, or a GS1 DataBar barcode can be substituted with a defined string.

uE serial				SE serial	
Parameter name	Para. code	Para. option	Para. value	Parameter (Para. No.)	Para. value
Prefix string setting  8001	0x1F 0x41	0-22 characters None	00-FF ₁₆ 00*	Prefix(0x69) Suffix1(0x68) Suffix2(0x6A)	0x00* 0x0A* 0x0D*
Suffix string setting  8002	0x1F 0x42	0-22 characters <ENTER>	00-FF ₁₆ 0D0A*	ScanDataTransmissionFormat (0xEB) ^{Note1} Prefix2~Prefix22 (0xF3 0x01~0x15) PrefixLen(0xF3 0x16) Suffix3~Suffix22 (0xF3 0x19~0x2C) SuffixLen(0xF3 0x2D) ^{Note2}	0x00* 0x41* 0x00* 0x41* 0x00*
Preamble string setting  8003	0x1F 0x43	0-22 characters None	00-FF ₁₆ 00*	Preamb1~Preamb22 (0xF3 0x2E~0x43) PreamblLen (0xF3 0x44)	0x41* 0x00*
Postamble string setting  8004	0x1F 0x44	0-22 characters None	00-FF ₁₆ 00*	Postamb1~Postamb22 (0xF3 0x45~0x5A) PostambLen (0xF3 0x5B)	0x41* 0x00*
Insert G1 string setting  8005	0x1F 0x45	0-22 characters None	00-FF ₁₆ 00*	InsertG1Str 1~22 (0xF3 0x5C~0x71) InsertG1StrLen (0xF3 0x72)	0x41* 0x00*
Insert G2 string setting  8006	0x1F 0x46	0-22 characters None	00-FF ₁₆ 00*	InsertG2Str 1~22 (0xF3 0x73~0x88) InsertG2StrLen (0xF3 0x89)	0x41* 0x00*
Insert G3 string setting  8007	0x1F 0x47	0-22 characters None	00-FF ₁₆ 00*	InsertG3Str 1~22 (0xF3 0x8A~0x9F) InsertG3StrLen (0xF3 0xA0)	0x41* 0x00*
Insert G4 string setting  8008	0x1F 0x48	0-22 characters None	00-FF ₁₆ 00*	InsertG4Str 1~22 (0xF3 0xA1~0xB6) InsertG4StrLen (0xF3 0xB7)	0x41* 0x00*



uE serial				SE serial	
Parameter name	Para. code	Para. option	Para. value	Parameter (Para. No.)	Para. value
FN1 substitution string setting  8009	0x1F 0x49	0-4 characters <SP>	00-FF ₁₆ 20*	FN1SubStr1~4 (0xF3 0xB9~0xBC) FN1SubStrLen (0xF3 0xBD)	0x41* 0x00*



Note 1: For uE serial, prefix and suffix can have up to 22 characters but for SE serial prefix can have one character and suffix has two characters. Because parameter structure of prefix and suffix is distinctly different between uE and SE serials, it is complicated for the mapping between two serials.

Note 2: Parameter values can be changed by: 1) scanning configuration barcodes, or 2) UE_PARAM_SEND command, or 3) SE_PARAM_SEND command. Once one of parameters 8001, 8002, 8201, 8202 is changed by scanning configuration barcode or by sending UE_PARAM_SEND command, the SE serial parameter ScanDataTransmissionFormat is set as 0xFF.

6-28 G1-G4 string position & Code ID position

Format of barcode data transmission:

Prefix	Code name	Preamble	Code ID	Code length	Code data	Code ID	Postamble	Suffix
--------	-----------	----------	---------	-------------	-----------	---------	-----------	--------

Insert G1/G2/G3/G4 string position: The engine offers 4 positions to insert strings among the barcode data string. In case of the insertion position is greater than the length of the barcode data string, the insertion of string is not effective.

Code ID position: It is allowed to select different code ID position/placement.



uE serial				SE serial	
Parameter name	Para. code	Para. option	Para. value	Parameter (Para. No.)	Para. value
Insert G1 string position 8101	0x1F 0xA5	00-99	00-99 00*	Insert G1 string position (0xF2 0xC0)	00-99 00*
Insert G2 string position 8102	0x1F 0xA6	00-99	00-99 00*	Insert G2 string position (0xF2 0xC1)	00-99 00*
Insert G3 string position 8103	0x1F 0xA7	00-99	00-99 00*	Insert G3 string position (0xF2 0xC2)	00-99 00*
Insert G4 string position 8104	0x1F 0xA8	00-99	00-99 00*	Insert G4 string position (0xF2 0xC3)	00-99 00*
Code ID position 8105	0x1F 0xA9	Before code data After code data	00* 01	Code ID position (0xF2 0xC4)	00* 01
Reserved 8106	0x1F 0xAA			-	-
Reserved 8107	0x1F 0xAB			-	-



6-29 String transmission

Note: The information in this chapter is closely related to the chapter of G1-G4 & FN1 substitution string setting.

Format of barcode data transmission:

Prefix	Code name	Preamble	Code ID	Code length	Code data	Code ID	Postamble	Suffix
--------	-----------	----------	---------	-------------	-----------	---------	-----------	--------

Preamble transmission: By setting Enable, preamble will be appended before the data transmitted.

Postamble transmission: By setting Enable, postamble will be appended after the data is transmitted.

Code ID transmission: Code ID can be transmitted in the format of either Proprietary ID or AIM ID. Refer to [1-2 Default settings for various types of barcode](#).

Code length transmission: The length of code data string can be transmitted before the code data when Enable is selected. The length is represented by a number with two digits.

Code name transmission: By setting Enable, code name will be transmitted before code data.

Case conversion: The characters within code data or the whole output string can be set in either upper case or lower case.

FN1 substitution transmission: The engine supports a FN1 substitution feature. The replacement string of FN1 can be chosen by user (see [6-27 G1-G4 & FN1 substitution string setting](#)).



%SETUP

uE serial				SE serial	
Parameter name	Para. code	Para. option	Para. value	Parameter (Para. No.)	Para. value
Prefix transmission 8201	0x20 0x09	Disable Enable	00* 01	Prefix(0x69) Suffix1(0x68) Suffix2(0x6A)	0x00* 0x0A* 0x0D*
Suffix transmission 8202	0x20 0x0A	Disable Enable	00* 01	ScanDataTransmissionFormat (0xEB) ^{Note1}	0X00*
Code name transmission 8203	0x20 0x0B	Disable Enable	00* 01	CodeNameTransmission (0xF2 0xC8)	00* 01
Preamble transmission 8204	0x20 0x0C	Disable Enable	00* 01	PreambleTransmission (0xF2 0xC9)	00* 01
Postamble transmission 8205	0x20 0x0D	Disable Enable	00* 01	PostambleTransmission (0xF2 0xCA)	00* 01
Code ID transmission 8206	0x20 0x0E	Disable Proprietary ID AIM ID	00* 01 02	Transmit Code ID Character (0x2D)	00* 02 01
Code length transmission 8207	0x20 0x0F	Disable Enable	00* 01	CodeLengthTransmission (0xF2 0xCB)	00* 01
Case conversion 8208	0x20 0x10	Disable Upper (data only) Lower (data only) Upper (whole string) Lower (whole string)	00* 01 02 03 04	CaseConversion (0xF2 0xCC)	00* 01 02 03 04
FN1 substitution transmission 8209	0x20 0x11	Disable Enable	00* 02	FN1 Substitution Transmission (0xF2 0xCD)	00* 02



%%%END

Note 1: For uE serial, prefix and suffix can have up to 22 characters but for SE serial prefix can have one character and suffix has two characters. Because parameter structure of prefix and suffix is distinctly different between uE and SE serials, it is a bit complicated for the mapping between two serials.

Note 2: Parameter values can be changed by: 1) scanning configuration barcodes, or 2) UE_PARAM_SEND command, or 3) SE_PARAM_SEND command. Once one of parameters 8001, 8002, 8201, 8202 is changed by scanning configuration barcode or by sending UE_PARAM_SEND command, the SE serial parameter ScanDataTransmissionFormat is set as 0xFF.

6-30 SE serial parameters list

Table 6-1 lists SE standard parameters compatible with uE serial.

Table 6-1 SE serial standard parameters

SE serial				uE serial	
Parameter	Para. No. (Hex)	Parameter value & option	Factory default	Factory default	Support
Beeper Volume	0x8C	0: High 1: Medium 2: Low	1 (Medium)	Same as left	No
Beeper Tone	0x91	0: Low Frequency 1: Medium Frequency 2: High Frequency	1 (Medium Frequency)	Same as left	No
Beeper Frequency Adjustment	0xF0 x91	0xFF(1230Hz)~0x7F(3770Hz) (unit 10Hz)	0 (2500 Hz)	Same as left	Yes
Laser On Time	0x88	0x00~0x63 (unit 100ms)	0x1E (3 s)	0x28 (4 s)	Yes
Aim Duration	0xED	0x00~0x63 (unit 100ms)	0 (0 s)	Same as left	No
Scan Angle	0xBF	0xB5 (Narrow 35 °) 0xB7 (Wide 47 °)	0xB7 (Wide)	Same as left	No
Power Mode	0x80	0: Continuous 1: Low	1 (Low)	Same as left	Yes
Trigger Mode	0x8A	0x00: Level 0x02: Pulse 0x04: Continuous 0x05: Alternate 0x07: Blinking 0x08: Host	0x00 (Level)	Same as left	Yes
Time-out Between Same Type of barcode	0x89	0x00~0x63 (unit 100ms)	0x0A (1s)	Same as left	Yes
Beep After Good Decode	0x38	0: Disable 1: Enable	1 (Enable)	Same as left	Yes
Transmit “No Read” Message	0x5E	0: Disable 1: Enable	0 (Disable)	Same as left	Yes
Parameter Scanning	0xEC	0: Disable 1: Enable	1(Enable)	Same as left	Yes
Linear Code Type Security Levels	0x4E	0x01: Linear Security Level 1 0x02: Linear Security Level 2 0x03: Linear Security Level 3 0x04: Linear Security Level 4	0x01 (Linear Security Level 1)	Same as left	No
Bi-directional Redundancy	0x43	0:Disalbe 1:Enable	0 (Disable)	Same as left	No
UPC/EAN					
UPC-A Read	0x01	0: Disable 1: Enable	1 (Enable)	Same as left	Yes
UPC-E Read	0x02	0: Disable	1 (Enable)	Same as left	Yes

SE serial				uE serial	
Parameter	Para. No. (Hex)	Parameter value & option	Factory default	Factory default	Support
		1: Enable			
UPC-E1 Read	0x0C	0: Disable 1: Enable	0 (Disable)	Same as left	Yes
EAN-8 Read	0x04	0: Disable 1: Enable	1 (Enable)	Same as left	Yes
EAN-13 Read	0x03	0: Disable 1: Enable	1 (Enable)	Same as left	Yes
Bookland EAN	0x53	0: Disable 1: Enable	0(Disable)	Same as left	Yes
Decode UPC/EAN Supplemental	0x10	0x00: Ignore UPC/EAN with Supplemental 0x02: Auto-discriminate UPC/EAN Supplemental 0x05: Enable 978 Supplemental	0x00 (Ignore)	Same as left	Yes
Decode UPC/EAN Supplemental Redundancy	0x50	0x00~0x63	7	Same as left	No
Transmit UPC-A Check Digit	0x28	0: Disable 1: Enable	1 (Enable)	Same as left	Yes
Transmit UPC-E Check Digit	0x29	0: Disable 1: Enable	1 (Enable)	Same as left	Yes
Transmit UPC-E1 Check Digit	0x2A	0: Disable 1: Enable	1 (Enable)	Same as left	Yes
UPC-A Preamble	0x22	0: Data 1: System Character + Data 2: Country Code+ System Character + Data	1 (System Character + Data)	Same as left	Yes
UPC-E Preamble	0x23	0: Data 1: System Character + Data 2: Country Code+ System Character + Data	1 (System Character + Data)	Same as left	Yes
UPC-E1 Preamble	0x24	0: Data 1: System Character + Data 2: Country Code+ System Character + Data	1 (System Character + Data)	Same as left	Yes
Convert UPC-E to A	0x25	0: Disable 1: Enable	0 (Disable)	Same as left	Yes
Convert UPC-E1 to A	0x26	0: Disable 1: Enable	0 (Disable)	Same as left	Yes
EAN-8 Zero Extend	0x27	0: Disable 1: Enable	0 (Disable)	Same as left	Yes
Convert EAN-8 to EAN-13 Type	0xE0	0: Type is EAN-13 1: Type is EAN-8	0(Type is EAN-13)	Same as left	No
UPC/ENA Security Level	0x4D	0x00: UPC/ENA Security Level 0 0x01: UPC/ENA Security Level 1 0x02: UPC/ENA Security Level 2 0x03: UPC/ENA Security Level 3	0(UPC/ENA Security Level 0)	Same as left	No

SE serial				uE serial	
Parameter	Para. No. (Hex)	Parameter value & option	Factory default	Factory default	Support
UCC Coupon Extended Code	0x55	0: Disable 1: Enable	0(Disable)	Same as left	No
Code 128					
Code-128 Read	0x08	0: Disable 1: Enable	1 (Enable)	Same as left	Yes
UCC/EAN-128 Read	0x0E	0: Disable 1: Enable	1 (Enable)	Same as left	Yes
ISBT 128 Read	0x54	0: Disable 1: Enable	1 (Enable)	Same as left	Yes
Code 39					
Code 39 Read	0x00	0: Disable 1: Enable ^[1]	1 (Enable)	Same as left	Yes
Trioptic Code 39 Read	0x0D	0: Disable 1: Enable ^[2]	0 (Disable)	Same as left	Yes
Convert Code 39 to Code 32	0x56	0: Disable 1: Enable	0 (Disable)	Same as left	Yes
Code 32 Prefix	0xE7	0: Disable 1: Enable	0 (Disable)	Same as left	Yes
Set Length(s) for Code 39	0x12 (L1) 0x13 (L2)	0x00~0x99 0x00~0x99 (L1>L2 is not supported)	0x02 0x37	0x01 0x63	Yes
Code 39 Check Digit Verification	0x30	0: Disable 1: Enable	0 (Disable)	Same as left	Yes
Transmit Code 39 Check Digit	0x2B	0: Disable 1: Enable	0 (Disable)	Same as left	Yes
Code 39 Full ASCII Conversion	0x11	0: Disable 1: Enable	0 (Disable)	Same as left	Yes
Code 93					
Code 93 Read	0x09	0: Disable 1: Enable	0 (Disable)	1 (Enable)	Yes
Set Length(s) for Code 93	0x1A(L1) 0x1B(L2)	0x00~0x63 0x00~0x63 (L1>L2 is not supported)	0x04 0x37	0x01 0x63	Yes
Code 11					
Code 11 Read	0x0A	0: Disable 1: Enable	0 (Disable)	Same as left	Yes
Set Lengths for Code 11	0x1C(L1) 0x1D(L2)	0x00~0x63 0x00~0x63 (L1>L2 is not supported)	0x04 0x37	0x04 0x63	Yes
Code 11 Check Digit Verification	0x34	0: Disable 1: One check digit 2: Two check digit	0 (Disable)	1 (One check digit)	Yes

SE serial				uE serial	
Parameter	Para. No. (Hex)	Parameter value & option	Factory default	Factory default	Support
Transmit Code 11 Check Digit(s)	0x2F	0: Disable 1: Enable	0 (Disable)	Same as left	Yes
Interleaved 2 of 5					
Interleaved 2 of 5 Read	0x06	0: Disable 1: Enable	1 (Enable)	Same as left	Yes
Set Length(s) for I 2 of 5	0x16 (L1) 0x17 (L2)	0x00~0x63 0x00~0x63 (L1>L2 is not supported)	0x0E 0x0E	0x06 0x63	Yes
I 2 of 5 Check Digit Verification	0x31	0: Disable 1: USS Check Digit 2: OPCC Check Digit	0 (Disable)	Same as left	Yes
Transmit I 2 of 5 Check Digit	0x2C	0: Disable 1: Enable	0 (Disable)	Same as left	Yes
Convert I 2 of 5 to EAN 13	0x52	0: Disable 1: Enable	0 (Disable)	Same as left	No
Discrete 2 of 5					
Discrete 2 of 5 Read	0x05	0: Disable 1: Enable	0 (Disable)	Same as left	Yes
Set Length(s) for D 2 of 5	0x14(L1) 0x15(L2)	0x00~0x63 0x00~0x63 (L1>L2 is not supported)	12 12	Same as left	Yes
Chinese 2 of 5 (China Post)					
Chinese 2 of 5 Read	0xF0 x98	0: Disable 1: Enable	0 (Disable)	1 (Enable)	Yes
Codabar					
Codabar Read	0x07	0: Disable 1: Enable	0 (Disable)	1 (Enable)	Yes
Set Lengths for Codabar	0x18 (L1) 0x19 (L2)	0x00~0x63 0x00~0x63 (L1>L2 is not supported)	0x05 0x37	0x04 0x63	Yes
CLSI Editing	0x36	0: Disable 1: Enable	0 (Disable)	Same as left	No
NOTIS Editing	0x37	0: Disable 1: Enable	0 (Disable)	Same as left	Yes
MSI					
MSI Read	0x0B	0: Disable 1: Enable	0 (Disable)	0 (Disable)	Yes
Set Length(s) for MSI	0x1E(L1) 0x1F(L2)	0x00~0x63 0x00~0x63 (L1>L2 is not supported)	0x06 0x37	0x04 0x63	Yes
MSI Check Digits	0x32	0: One digit 1: Two digit	0	0xFF	Yes

SE serial				uE serial	
Parameter	Para. No. (Hex)	Parameter value & option	Factory default	Factory default	Support
		0xFF: (No MSI Check Digit)			
Transmit MSI Check Digit	0x2E	0: Disable 1: Enable	0 (Disable)	Same as left	Yes
MSI Check Digit Algorithm	0x33	0: Mod10/Mod11 1: Mod10/Mod10	1 (Mod 10/Mod 10)	Same as left	Yes
GS1 DataBar (formerly RSS)					
GS1 DataBar (GS1 DataBar Truncated) Read	0xF0 x52	0: Disable 1: Enable	0 (Disable)	1 (Enable)	Yes
GS1 DataBar Limited Read	0xF0 x53	0: Disable 1: Enable	0 (Disable)	1 (Enable)	Yes
GS1 DataBar Expanded Read	0xF0 x54	0: Disable 1: Enable	0 (Disable)	1 (Enable)	Yes
Convert GS1 DataBar to UPC/EAN	0xF0 x8D	0: Disable 1: Enable	0 (Disable)	Same as left	Yes
Data options					
Transmit Code ID Character	0x2D	0: None 1: AIM code ID 2: User Defined ID	0 (None)	Same as left	Yes
Prefix/ Suffix Values					
Prefix	0x69	0x00~0x7F	0x00 (NULL)	0x00(NULL)	Yes
Suffix 1	0x68	0x00~0x7F	0x0A (LF)	0x0D (CR)	
Suffix 2	0x6A	0x00~0x7F	0x0D (CR)	0x0A (LF)	
Scan Data Transmission Format	0xEB	0x00: Data Only 0x01: Data + Suffix1 0x02: Data + Suffix2 0x03: Data + Suf1+Suf2 0x04: Prefix+Data 0x05: Prefix+Data+Suf1 0x06: Prefix+Data+Suf2 0x07: Prefix + Data + Suf1 + Suf2	0x00 (Data Only)	Same as left	Yes
Serial interface					
Baud Rate	0x9C	0x03: 1200 0x04: 2400 0x05: 4800 0x06: 9600 0x07: 19200 0x08: 38400 0x09: 57600 0x0A: 115200	0x06 (9600)	Same as left	Yes
Parity	0x9E	0x00: Odd 0x01: Even 0x04: None	0x04 (None)	Same as left	Yes
Software Handshaking	0x9F	0: Disable	1 (Enable)	Same as left	Yes

SE serial				uE serial	
Parameter	Para. No. (Hex)	Parameter value & option	Factory default	Factory default	Support
		1: Enable			
Decode Data Packet Format	0xEE	0: Raw 1: Packeted	0 (Raw)	Same as left	Yes
Host Serial Response Time-out	0x9B	0x00~0x63 (unit 100ms)	0x14 (2 sec)	Same as left	Yes
Stop Bit Select	0x9D	1: One 2: Two	1 (One)	Same as left	Yes
Intercharacter Delay	0x6E	00~99 (unit 1ms) ^[1]	0 (0 ms)	Same as left	Yes
Host Character Time-out	0xEF	00~99(unit 10ms) ^[1]	0x14 (200 ms)	Same as left	Yes
Event reporting					
Decode Event	0xF0 x00	0: Disable 1: Enable	0 (Disable)	Same as left	No
Boot Up Event	0xF0 x02	0: Disable 1: Enable	0 (Disable)	Same as left	Yes
Parameter Event	0xF0 x03	0: Disable 1: Enable	0 (Disable)	Same as left	No
Note 1: If Trioptic Code 39 read is set Enable, Code 39 read is forced Enable.					
Note 2: If Code 39 read is set Disable, Trioptic Code 39 read is forced Disable.					

Table 6-2 lists SE serial extension parameters compatible with uE serial.

Table 6-2 SE serial extension parameters

SE serial				uE serial
Parameter	Para. code (Hex)	Parameter value & option	Factory default	Factory default
LED ON duration	0xF2 0x20	0x01~0x63 (unit 100ms)	0x0A (1.0 sec)	same as left
Double confirm	0xF2 0x10	00~09 (00: No)	0	same as left
Global max. code length	0xF2 0x11	0x04~0x63	0x63	same as left
Global min. code length	0xF2 0x12	0x01~0x63	4	same as left
Global G1-G4 String selection	0xF2 0x13	(Note that following data should be in Hex format.) 00/01/02/03/04/ 10/11/12/13/14/ 20/21/22/23/24/ 30/31/32/33/34/ 40/41/42/43/44/	0	same as left
Element amendment	0xF2 0x14	0: Disable 1: Enable	1 (Enable)	same as left
Printable character only	0xF2 0x15	0: Disable 1: Enable	0 (Disable)	same as left
Decoder optimization	0xF2 0x16	0: Disable 1: Enable	1 (Enable)	same as left
UPC/EAN				
UPC-A Check Digit verification	0xF2 0x29	0: Disable 1: Enable	1 (Enable)	same as left
UPC-A Code ID	0xF2 0x2B	0x00-0xFF	<A> (0x41)	same as left
UPC-A Insert Group Selection	0xF2 0x2C	same as "Global G1-G4 String selection"	0	same as left
UPC-E Check digit verification	0xF2 0x30	0: Disable 1: Enable	1 (Enable)	same as left
UPC-E Code ID	0xF2 0x32	0x00-0xFF	<D> (0x44)	same as left
UPC-E Insert Group Selection	0xF2 0x33	same as "Global G1-G4 String selection"	0	same as left
UPC-E1_CheckDigitVerification	0xF2 0xBD	0: Disable 1: Enable	1 (Enable)	same as left
UPC-E1 CodeIDSetting	0xF2 0xBE	0x00~0xFF	<D> (0x44)	<A> (0x41)
UPC-E1 InsertGroupSelection	0xF2 0xBF	same as "Global G1-G4 String selection"	0	same as left
EAN-13 Check Digit Verification	0xF2 0x39	0: Disable 1: Enable	1 (Enable)	same as left
Transmit EAN-13 Check Digit	0xF2 0x3A	0: Disable 1: Enable	1 (Enable)	same as left
EAN-13 Code ID	0xF2 0x3B	0x00-0xFF	<A> (0x41)	same as left

SE serial				uE serial
Parameter	Para. code (Hex)	Parameter value & option	Factory default	Factory default
EAN-13 Insert Group Selection	0xF2 0x3C	same as “Global G1-G4 String selection”	0	same as left
ISBN/ISSN Code ID	0xF2 0x3D	0x00-0xFF		<L>
EAN-8 Check Digit Verification	0xF2 0x40	0: Disable 1: Enable	1 (Enable)	same as left
Transmit EAN-8 Check Digit	0xF2 0x41	0: Disable 1: Enable	1 (Enable)	same as left
EAN-8 Code ID	0xF2 0x42	0x00-0xFF	<C> (0x43)	<A> (0x41)
EAN-8 Insert Group Selection	0xF2 0x43	same as “Global G1-G4 String selection”	0	same as left
Code 128				
Code-128 Check Digit Verification	0xF2 0x70	0: Disable 1: Enable	1 (Enable)	same as left
Transmit Code-128 Check Digit	0xF2 0x71	0: Disable 1: Enable	0 (Disable)	same as left
Set Lengths for Code-128	0xF2 0x72(L1) 0xF2 0x73(L2)	0x00~0x63 0x00~0x63 (L1>L2 is not supported)	01 99(0x63)	0 0
Code-128 Code ID	0xF2 0x74	0x00~0xFF	<K> (0x4B)	<D> (0x44)
Code-128 Insert Group Selection	0xF2 0x75	same as “Global G1-G4 String selection”	0	same as left
Code-128 Truncate Leading Zeros	0xF2 0x76	0: Disable 1: All leading “0”s 2: Only the first “0”	0 (Disable)	same as left
UCC/EAN 128				
UCC_EAN128 Check Digit Verification	0xF2 0x98	0: Disable 1: Enable	1 (Enable)	same as left
Transmit UCC_EAN128 Check Digit	0xF2 0x99	0: Disable 1: Enable	0 (Disable)	same as left
Set Lengths for UCC_EAN128	0xF2 0x9A(L1) 0xF2 0x9B(L2)	0x00~0x63 0x00~0x63 (L1>L2 is not supported)	0x01 0x63	0 0
UCC_EAN128 Code ID	0xF2 0x9C	0x00~0xFF	<K> (0x4B)	same as left
UCC_EAN128 Insert Group Selection	0xF2 0x9D	same as “Global G1-G4 String selection”	0	same as left
UCC_EAN128 Truncate Leading Zeros	0xF2 0x9E	0:Disable 1:All Leading “0”s 2:Only the first “0”	0 (Disable)	same as left
ISBT 128				
ISBT 128_Check DigitVerification	0xF2 0xB6	0: Disable 1: Enable	1 (Enable)	same as left
ISBT 128_Transmit	0xF2 0xB7	0: Disable	0 (Disable)	same as left

SE serial				uE serial
Parameter	Para. code (Hex)	Parameter value & option	Factory default	Factory default
CheckDigit		1: Enable		
Set Lengths for ISBT 128	0xF2 0xB8(L1) 0xF2 0xB9(L2)	0x00~0x63 0x00~0x63 (L1>L2 is not supported)	01 99 (0x63)	0 0
ISBT 128_CodeID	0xF2 0xBA	0x00~0xFF	<K> (0x4B)	<D> (0x44)
ISBT 128_Insert GroupSelection	0xF2 0xBB	same as "Global G1-G4 String selection"	0	same as left
UK Plessey				
UK_Plessey Read	0xF2 0x90	0: Disable 1: Enable	0 (Disable)	same as left
UK_Plessey Check Digit Verification	0xF2 0x91	0: Disable 1: Enable	1 (Enable)	same as left
Transmit UK_Plessey Check Digit	0xF2 0x92	0: Disable 1: Enable	0 (Disable)	same as left
Set Length(s) for UK_Plessey	0xF2 0x93(L1) 0xF2 0x94(L2)	0x00~0x63 0x00~0x63 (L1>L2 is not supported)	0x01 0x63	0 0
UK_Plessey Code ID	0xF2 0x95	0x00~0xFF	<U> (0x55)	same as left
UK_Plessey Insert Group Selection	0xF2 0x96	same as "Global G1-G4 String selection"	0	same as left
Code 39				
Code 39 Code ID	0xF2 0x49	0x00~0xFF	<M> (0x4D)	 (0x42)
Code 39 Insert Group Selection	0xF2 0x4A	same as "Global G1-G4 String selection"	0	same as left
Code 39 Start/End Transmission	0xF2 0x4B	0: Disable 1: Enable	0 (Disable)	same as left
Code 39 Star As Data	0xF2 0x4C	0: Disable 1: Enable	0 (Disable)	same as left
Trioptic Code 39 Start/End transmission	0xF2 0x4D	0: Disable 1: Enable	0 (Disable)	same as left
Code 93				
Code 93 Check Digit Verification	0xF2 0x79	0: Disable 1: Enable	1 (Enable)	same as left
Transmit Code 93 Check Digit	0xF2 0x7A	0: Disable 1: Enable	0 (Disable)	same as left
Code 93 Code ID	0xF2 0x7B	0x00~0xFF	<L> (0x4C)	<E> (0x45)
Code 93 Insert Group Selection	0xF2 0x7C	same as "Global G1-G4 String selection"	0	same as left
Code 11				
Code 11 Code ID	0xF2 0x80	0x00~0xFF	<V> (0x56)	<H> (0x48)
Code 11 Insert Group Selection	0xF2 0x81	same as "Global G1-G4 String selection"	0	same as left

SE serial				uE serial
Parameter	Para. code (Hex)	Parameter value & option	Factory default	Factory default
Industrial 2 of 5				
Industrial 2 of 5 Code ID	0xF2 0x50	0x00~0xFF	<I> (0x49)	<F> (0x46)
Industrial 2 of 5 Insert Group Selection	0xF2 0x51	same as “Global G1-G4 String selection”	0	same as left
Industrial 2 of 5 Read	0x05	0: Disable 1: Enable	0 (Disable)	same as left
Set Lengths for Industrial 2 of 5	0x14 (L1)	0x00~0x63	04	12
	0x15 (L2)	0x00~0x63 (L1>L2 is not supported)	99(0x63)	12
Industrial 2 of 5 Code ID	0xF2 0x5B	0x00~0xFF	<G> (0x47)	same as left
Industrial 2 of 5 Insert Group selection	0xF2 0x5C	same as “Global G1-G4 String selection”	0	same as left
Matrix 2 of 5				
Matrix 2 of 5 Read	0xF2 0x60	0: Disable 1: Enable	1 (Enable)	same as left
Matrix 2 of 5 Check Digit Verification	0xF2 0x61	0: Disable 1: Enable	0 (Disable)	same as left
Transmit Matrix 2 of 5 Check Digit	0xF2 0x62	0: Disable 1: Enable	0 (Disable)	same as left
Set Lengths for Matrix 2 of 5	0xF2 0x63(L1)	0x00~0x63	06	0
	0xF2 0x64(L2)	0x00~0x63 (L1>L2 is not supported)	0x63	0
Matrix 2 of 5 Code ID	0xF2 0x65	0x00~0xFF	<X> (0x58)	same as left
Matrix 2 of 5 Insert Group Selection	0xF2 0x66	same as “Global G1-G4 String selection”	0	same as left
China Post				
ChinaPostCode ID	0xF2 0xA4	0x00~0xFF	<T> (0x54)	same as left
ChinaPost Insert Group Selection	0xF2 0xA5	same as “Global G1-G4 String selection”	0	same as left
Codabar				
Codabar Check Digit Verification	0xF2 0x68	0: Disable 1: Enable	0 (Disable)	same as left
Transmit Codabar Check Digit	0xF2 0x69	0: Disable 1: Enable	0 (Disable)	same as left
Codabar Code ID	0xF2 0x6A	0x00~0xFF	<N> (0x4E)	<C> (0x43)
Codabar Insert Group Selection	0xF2 0x6B	same as “Global G1-G4 String selection”	0	same as left
Codabar Start End Type	0xF2 0x6C	0: ABCD/ABCD 1: abcd/abcd 2: ABCD/TN*E 3: abcd/tn*e	0	same as left
Codabar Start End Character	0xF2 0x6D	0: Disable	0 (Disable)	same as left

SE serial				uE serial
Parameter	Para. code (Hex)	Parameter value & option	Factory default	Factory default
Equality		1: Enable		
MSI				
MSI_CodeIDSetting	0xF2 0x88	0x00~0xFF	<O> (0x4F)	<J> (0x4A)
MSI_InsertGroupSelection	0xF2 0x89	same as “Global G1-G4 String selection”	0	same as left
GS1 Databar (formerly RSS)				
GS1 DataBar Code ID	0xF2 0xA8	0x00~0xFF	<R> (0x52)	same as left
GS1 DataBar Insert Group Selection	0xF2 0xA9	same as “Global G1-G4 String selection”	0	same as left
GS1 DataBar Limited Code ID	0xF2 0xAB	0x00~0xFF	<R> (0x52)	same as left
GS1 DataBar Limited Insert Group Selection	0xF2 0xAC	same as “Global G1-G4 String selection”	<R> (0x52)	same as left
Set Lengths for GS1 DataBar Expanded	0xF2 0xB0(L1) 0xF2 0xB1(L2)	0x00~0x63 0x00~0x63 (L1>L2 is not supported)	01 99 (0x63)	0 0
GS1 DataBar Expanded Code ID	0xF2 0xB2	0x00~0xFF	<R> (0x52)	same as left
GS1 DataBar Expanded Insert Group Selection	0xF2 0xB3	same as “Global G1-G4 String selection”	0	same as left
GS1 DataBar Expanded to UCC/EAN	0xF2 0xB4	0: Disable 1: Enable	0 (Disable)	same as left
Data options				
Prefix 2~Prefix22	0xF3 0x01~ 0xF3 0x15	0x00~0xFF	0x41 (A)	same as left
Prefix Length	0xF3 0x16	0x00~0x16	0	same as left
Suffix 3~Suffix22	0xF3 0x19~ 0xF3 0x2C	0x00~0xFF	0x41 (A)	same as left
Suffix Length	0xF3 0x2D	0x00~0x16	0	same as left
Preamble String Setting1~ Preamble String Setting22	0xF3 0x2E~ 0xF3 0x43	0x00~0xFF	0x41 (A)	same as left
Preamble String Length	0xF3 0x44	0x00~0x16	0	same as left
Postamble String Setting1~ Postamble String Setting22	0xF3 0x45~ 0xF3 0x5A	0x00~0xFF	0x41 (A)	same as left
Postamble String Length	0xF3 0x5B	0x00~0x16	0	same as left
Insert G1 String Setting1~ Insert G1 String Setting22	0xF3 0x5C~ 0xF3 0x71	0x00~0xFF	0x41 (A)	same as left
Insert G1 String Length	0xF3 0x72	0x00~0x16	0	same as left
Insert G2 String Setting1~ Insert G2 String Setting22	0xF3 0x73~ 0xF3 0x88	0x00~0xFF	0x41 (A)	same as left
Insert G2 String Length	0xF3 0x89	0x00~0x16	0	same as left
Insert G3 String Setting1~ Insert G3 String Setting22	0xF3 0x8A~ 0xF3 0x9F	0x00~0xFF	0x41 (A)	same as left
Insert G3 String Length	0xF3 0xA0	0x00~0x16	0	same as left

SE serial				uE serial
Parameter	Para. code (Hex)	Parameter value & option	Factory default	Factory default
Insert G4 String Setting 1~ Insert G4 String Setting 22	0xF3 0xA1~ 0xF3 0xB6	0x00~0xFF	0x41 (A)	same as left
Insert G4 String Length	0xF3 0xB7	0x00~0x16	0	same as left
FN1 Substitution String Setting 1~4	0xF3 0xB9 0xF3 0xBA 0xF3 0xBB 0xF3 0xBC	0x00~0xFF	0x41 (A) 0x41 (A) 0x41 (A) 0x41 (A)	same as left
FN1 Substitution String Setting Length	0xF3 0xBD	00~04	0	same as left
Code Name Transmission	0xF2 0xC8	0: Disable 1: Enable	0 (Disable)	same as left
Preamble Transmission	0xF2 0xC9	0: Disable 1: Enable	0 (Disable)	same as left
Postamble Transmission	0xF2 0xCA	0: Disable 1: Enable	0 (Disable)	same as left
Code Length Transmission	0xF2 0xCB	0: Disable 1: Enable	0 (Disable)	same as left
Case Conversion	0xF2 0xCC	0: Disable 1: Upper(data only) 2: Lower(data only) 3: Upper(whole string) 4: Lower(whole string)	0	same as left
FN1 substitution transmission	0xF2 0xCD	0: Disable 2: RS-232	0	same as left
Insert G1 String position	0xF2 0xC0	0x00~0x63	0	same as left
Insert G2 String position	0xF2 0xC1	0x00~0x63	0	same as left
Insert G3 String position	0xF2 0xC2	0x00~0x63	0	same as left
Insert G4 String position	0xF2 0xC3	0x00~0x63	0	same as left
Code ID position	0xF2 0xC4	0: Before code data 1: After code data	0	same as left

7 Serial Communication Interface

This section describes the system requirements of the Serial Communication Interface (SCI), which provides a communication link between an engine and a host via UART. SCI allows the host to configure the engine.

All communication between the engine and the host occur over the hardware interface lines using the SCI protocol.

The host and the engine exchange messages in packets. A packet is a collection of bytes framed by the proper SCI protocol formatting bytes. The maximum number of bytes per packet allowed by the SCI protocol for any transaction is 257 (255 bytes of data + 2 bytes of checksum).

Decode data may be sent as ASCII data (unpacked), or as part of a larger message (packed), depending on the engine configuration.

SCI performs the following functions:

1. Maintains a bi-directional communication interface between the host and the engine.
2. Allows the host to send commands which can configure the engine.
3. Passes decoded data from the engine to the host. The data is in SCI packet format or in ASCII format.

The SCI environment consists of an engine, a serial cable which attaches to a host.

The SCI interface transmits all decode data including special formatting (e.g., AIM ID). The format of this data can be controlled via parameter settings. The engine may also send parameter information, product identification information or event codes to the host.

All commands sent between the engine and host must use the format described in [7-1 SCI message formats](#). [8 SCI Transactions](#) describes the required sequence of messages in a number of specific cases.

Table 7-1 lists all the SCI commands supported by the engine. It identifies the SCI partner allowed to send a command of each type. The host transmits type H command, the engine transmits type E command, and either partner can transmit Host/Engine (H/E) types.

The following sections describe each of the SCI messages that can be communicated between engine and host.

See [8 SCI Transactions](#) for the protocol required to transmit these messages.

Table 7-1 SCI commands

Name	Type	Opcode	Description	Support
AIM_OFF	H	0xC4	Deactivate aim pattern	Reserved
AIM_ON	H	0xC5	Activate aim pattern.	Reserved
BEEP	H	0xE6	Sound the beeper.	Yes
CMD_ACK	H/E	0xD0	Positive acknowledgment of received packet.	Yes
CMD_NAK	H/E	0xD1	Negative acknowledgment of received packet.	Yes
DECODE_DATA	E	0xF3	Decode data in SCI packet format.	Yes
EVENT	E	0xF6	Event indicated by associated event code.	Yes
LED_OFF	H	0xE8	De-activate LED output.	Yes
LED_ON	H	0xE7	Activate LED output.	Yes
SE_PARAM_DEFAULTS	H	0xC8	Load uE serial Default	Yes
SE_PARAM_REQUEST	H	0xC7	Request values of SE serial parameters.	Yes
SE_PARAM_SEND	H/E	0xC6	Send SE serial parameter values.	Yes
REQUEST_REVISION	H	0xA3	Request the engine's configuration.	Yes
REPLY_REVISION	E	0xA4	Reply to REQ_REV contains engine's software/ hardware configuration.	Yes
SCAN_DISABLE	H	0xEA	Prevent the operator from scanning barcodes.	Yes
SCAN_ENABLE	H	0xE9	Permit barcode scanning.	Yes
SLEEP	H	0xEB	Request to place the engine into low power.	Yes
START_DECODE	H	0xE4	Tell engine to attempt to decode a barcode.	Yes
STOP_DECODE	H	0xE5	Tell engine to abort a decode attempt.	Yes
WAKEUP	H	N/A	Wakeup engine after it's been powered down.	Yes
SE_CUSTOM_DEFAULTS	H	0x12	Custom defaults option to write/restore <small>Note1</small>	Yes
UE_PARAM_DEFAULTS	H	0xD8	Set uE parameter default values.	Yes
UE_PARAM_REQUEST	H	0xD7	Request values of certain parameters.	Yes
UE_PARAM_SEND	H/E	0xD6	Send uE parameter values.	Yes
UE_CUSTOM_DEFAULTS	H	0x22	Custom defaults option to write/restore <small>Note2</small>	Yes
MANUFACTURE_INFO_REQUEST	H	0xB7	Request information of manufacture	Yes
MANUFACTURE_INFO_SEND	E	0xB6	Respond to a MANUFACTURE_REQUEST	Yes
<p>Note1: If no customer defaults are set, Restore default settings as SE serial default.</p> <p>Note2: If no customer defaults are set, Restore default settings as uE serial default.</p>				

7-1 SCI message formats

The general packet format for SCI message is as following:

Length	Opcode	Message Source	Status	Data	Checksum
--------	--------	----------------	--------	------	----------

Table 7-2 lists the descriptions of fields that occur in all messages. These descriptions are repeated for each opcode. For messages that use the Data field, the specific type of data is described in that field in later sections.

Table 7-2 Field descriptions

Field Name	Format	Sub-Field	Description
Length	1 Byte	Length	Length of message not including the check sum bytes. Maximum value is 0xFF.
Opcode	1 Byte	See Table 7-1 for details.	Identifies the command being sent.
Message Source	1 Byte	0x00 = Engine 0x04 = Host	Identifies where the message is coming from.
Status	Bit 0	Retransmit	0 = First time packet is sent 1 = Subsequent transmission attempts
	Bit 1	Reserved	Always set to zero
	Bit 2	Reserved	Always set to zero
	Bit 3	Change Type (applies to parameters)	0 = Temporary change 1 = Permanent change
	Bits 4 - 7		Unused bits must be set to 0.
Data	Variable number of bytes	See individual sections for details.	
Checksum	2 Bytes	2's complement sum of message contents excluding checksum.	Checksum of message formatted as High-Byte Low-Byte
<p>Note: The checksum is a 2 byte checksum and must be sent as High-Byte followed by Low-Byte. Checksum = 0x10000 – Length - Opcode - Message Source - Status – Data.</p>			

7-2 AIM_OFF

Description: Turn off aiming pattern

 Note that this command is currently reserved.

7-3 AIM_ON

Description: Turn on aiming pattern

 Note that this command is currently reserved.

7-4 BEEP

Description: Ask the engine to sound the beeper

Packet Format

Length	Opcode	Message Source	Status	Beep Code	Checksum
0x05	0xE6	0x04			

Field Descriptions

Field Name	Format	Size	Description
Length	Length of message (not including checksum).	1 Byte	Length Field
Opcode	0xE6	1 Byte	Identifies this opcode type.
Message Source	0x04 = Host	1 Byte	Identifies where the message comes from.
Status	Bit 0: Retransmit Bit 1-7: unused	1 Byte	Identifies the transmission status. All unused bits must be set to 0.
Beep Code	See Table 7-3.	1 Byte	Number that identifies a beep sequence.
Checksum	2's complement sum of message contents excluding checksum.	2 Bytes	Checksum of message.

This command instructs the engine to sound the beep sequence indicated by the Beep Code field.

In Table 7-3, Duration is the length of a sound, Pitch (a relative term) is the pitch of the sound, and Number of Beeps indicates the times of a repeated beep pitch at the specified duration.

Table 7-3 Beep code definitions

Beep Code	Duration (ms)	Pitch	No. of beeps	Beep Code	Duration (ms)	Pitch	No. of beeps
0x00	72	High	1 (Short)	0x0D	1569	High	4 (Long)
0x01	193	High	2 (Short)	0x0E	2011	High	5 (Long)
0x02	315	High	3 (Short)	0x0F	241	Low	1 (Long)
0x03	436	High	4 (Short)	0x10	684	Low	2 (Long)
0x04	558	High	5 (Short)	0x11	1126	Low	3 (Long)
0x05	72	Low	1 (Short)	0x12	1569	Low	4 (Long)
0x06	193	Low	2 (Short)	0x13	2011	Low	5 (Long)
0x07	315	Low	3 (Short)	0x14	382	Hi-Lo-Hi-Lo	4 (Fast Warble)
0x08	436	Low	4 (Short)	0x15	965	Hi-Lo-Hi-Lo	4 (Slow Warble)
0x09	558	Low	5 (Short)	0x16	191	Hi-Lo	2 (Mix 1)
0x0A	241	High	1 (Long)	0x17	191	Lo-Hi	2 (Mix 2)
0x0B	684	High	2 (Long)	0x18	292	Hi-Lo-Hi	3 (Mix 3)
0x0C	1126	High	3 (Long)	0x19	282	Lo-Hi-Lo	3 (Mix 4)

For example:

Length	Opcode	Message Source	Status	Beep Code	Checksum
0x05	0xE6	0x04	0x00	0x06	0xFF 0x0B

The method of calculating Checksum:

Checksum=0x10000-0x05-0xE6-0x04-0x00-0x06=0xFF0B.

Host Requirements

The host sends this command to cause the engine to beep. The host may also send these beep codes as part of the SE_PARAM_SEND (or UE_PARAM_SEND) directive.

Engine Requirements

When the engine receives this command, it beeps the sequence provided in the BEEP directive. If ACK/NAK handshaking is enabled and a valid beep code (see [Table 7-3 Beep code definitions](#)) is received, the engine replies an ACK. Otherwise it sends NAK_DENIED (see [7-6 CMD_NAK](#)).

7-5 CMD_ACK

Description: Positive acknowledgment of received packet

Packet Format

Length	Opcode	Message Source	Status	Checksum
0x04	0xD0			

Field Descriptions

Field Name	Format	Size	Description
Length	Length of message (not including checksum).	1 Byte	Length Field
Opcode	0xD0	1 Byte	Identifies this Opcode type.
Message Source	0x00 = Engine 0x04 = Host	1 Byte	Identifies where the message is coming from.
Status	Bit 0: Retransmit Bit 1-7: unused	1 Byte	Identifies the transmission status. All unused bits must be set to 0.
Checksum	2's complement sum of message contents excluding	2 Bytes	Checksum of message.

CMD_ACK message is sent to the SCI packet transmitter when the received packet passes the checksum check and no negative acknowledgment conditions apply. If the data to be sent is in response to a command (e.g. REQUEST_REVISION), CMD_ACK message is not in need.

✚ ACK/NAK handshaking can be disabled, but this is not recommended.

✚ It is not necessary to respond to a valid ACK or NAK message.

For example:

Length	Opcode	Message Source	Status	Checksum
0x04	0xD0	0x00	0x00	0xFF 0x2C

Host Requirements

The host must send a CMD_ACK or response data within the programmable **Host Serial Response Time-out** to acknowledge receipt of all messages, unless noted otherwise in the message description section. If the host sends data and does not receive a response within the programmable **Host Serial Response Time-out**, it resends the message (with the retransmit status bit set) before declaring a failure.

The host should limit the number of retries.

Engine Requirements

The engine must send a CMD_ACK or response data within the programmable **Host Serial Response Time-out** to acknowledge receipt of all messages, unless noted otherwise in the message description section. If the engine does not receive an ACK within this time period, it sends the previous message again. The engine retries twice more (with the retransmit status bit set) before declaring a transmit error.

7-6 CMD_NAK

Description: Negative acknowledgment of received packet

Packet Format

Length	Opcode	Message Source	Status	Cause	Checksum
0x05	0xD1				

Field Descriptions

Field Name	Format	Size	Description
Length	Length of message (not including checksum).	1 Byte	Length Field
Opcode	0xD1	1 Byte	Identifies this opcode type.
Message Source	0x00 = Engine 0x04 = Host	1 Byte	Identifies where the message is coming from.
Status	Bit 0: Retransmit Bit 1-7: unused	1 Byte	Identifies the transmission status. Unused bits must be set to 0.
Cause	Reason code	1 Byte	Identifies the reason the NAK occurred: 0 = Reserved 1 = (RESEND) Checksum failure 2 = (BAD_CONTEXT) Unexpected or Unknown message 3 = Reserved 4 = Reserved 5 = Reserved 6 = (DENIED) Host Directive Denied 7 = Reserved 8 = Reserved 9 = Reserved
Checksum	2's complement sum of message contents excluding checksum.	2 Bytes	Checksum of message.

This message is sent when the received packet fails the checksum verification or some error occurred while handling the message.

✚ ACK/NAK handshaking can be disabled, but this is not recommended.

✚ It is not necessary to respond to a valid ACK or NAK message.

For example:

Length	Opcode	Message Source	Status	Cause	Checksum
0x05	0xD1	0x00	0x00	0x01 (Checksum failure)	0xFF 0x29

Table 7-4 describes NAK types supported by the engine.

Table 7-4 Engine-supported NAK types

NAK Type	Meaning	Receiver Action
NAK_RESEND	Checksum incorrect.	Ensure checksum is correct. Limit number of resends. Send packet again with resend bit set.
NAK_DENIED	Host is unable to comply with the requested message (e.g., beep code is out of range).	Do not send the same message again. Developer should ensure the proper message is sent.
NAK_BAD_CONTEXT	Host does not recognize the command.	

The engine only resends a message twice. If the message is not sent successfully either time, the engine declares a transmit error and issues transmit error beeps (LO-LO-LO-LO).

7-7 DECODE_DATA

Description: Decode data in SCI packet format

Packet Format

Length	Opcode	Message Source	Status	Code Type	Decode Data	Checksum
	0xF3	0x00				

Field Descriptions

Field Name	Format	Size	Description
Length	Length of message (not including checksum).	1 Byte	Length Field
Opcode	0xF3	1 Byte	Identifies this opcode type.
Message Source	0x00 = Engine	1 Byte	Identifies where the message is coming from.
Status	Bit 0: Retransmit Bits 1-7: unused	1 Byte	Identifies the transmission status. Unused bits must be set to 0.
Code Type	See Table 7-5	1 Byte	Identifies the scanned data code type.
Decode Data	<data>	Variable	Data is decoded data including prefix and suffix sent in ASCII format.
Checksum	2's complement sum of message contents excluding checksum.	2 Bytes	Checksum of message.

The engine uses this opcode when packeted data is selected to send decoded barcode data to the host.

The decoded message is contained in the Decode Data field.

Table 7-5 lists all code types supported by the engine. The associated hexadecimal value for each type of barcode (as required) is entered in the Barcode Type field.

Table 7-5 List of supported Code Types

Not Applicable	0x00	Code 11	0x0C
Code 39	0x01	EAN 13	0x0B
Codabar	0x02	EAN 13 with 2 Supps.	0x4B
Code 128	0x03	EAN 13 with 5 Supps.	0x8B
Discrete 2 of 5	0x04	MSI	0x0E
IATA 2 of 5	0x05	EAN 128	0x0F
Interleaved 2 of 5	0x06	UPC E1	0x10
Code 93	0x07	UPC E1 with 2 Supps.	0x50
UPC A	0x08	UPC E1 with 5 Supps.	0x90
UPC A with 2 Supps.	0x48	Trioptic Code 39	0x15
UPC A with 5 Supps.	0x88	Bookland EAN	0x16
UPC E0	0x09	Coupon Code	0x17 (Reserved)
UPC E0 with 2 Supps.	0x49	GS1 DataBar Limited (RSS-Limited)	0x31
UPC E0 with 5 Supps.	0x89	GS1 DataBar (RSS-14)	0x30
EAN 8	0x0A	GS1 DataBar Expanded (RSS-Expanded)	0x32
EAN 8 with 2 Supps.	0x4A	Matrix 2 of 5	0x0D

EAN 8 with 5 Supps.	0x8A	Code 32	0x20
UK Plessey	0x13	China Post (Chinese 2 of 5)	0x72
ISBT128	0x19		

Host Requirements

If **Decode Event** parameter (see [Table 6-1 SE serial standard parameters](#)) is enabled, the Decode Event message (see [7-8 EVENT](#)) is received prior to the DECODE_DATA message. If ACK/NAK handshaking is enabled, the host responds to each of these messages.

Engine Requirements

Decode data is sent in this format if packeted decode data is selected via parameter. The host responds to this message with a CMD_ACK, if ACK/NAK handshaking is enabled.

7-8 EVENT

Description: Indicate selected events occurred

Packet Format

Length	Opcode	Message Source	Status	Event Code	Checksum
0x05	0xF6	0x00			

Field Descriptions

Field Name	Format	Size	Description
Length	Length of message (not including checksum).	1 Byte	Length Field
Opcode	0xF6	1 Byte	Identifies this opcode type.
Message Source	0x00 = Engine	1 Byte	Identifies where the message is coming from.
Status	Bit 0: Retransmit Bit 1-7: Unused	1 Byte	Identifies the transmission status. Unused bits must be set to 0.
Event Code	Type of Event Code.	1 Byte	*
Checksum	2's complement sum of message contents excluding checksum.	2 Bytes	Checksum of message.

*Event codes description:

Event Class	Event	Code Reported	Support
Decode Event	Non-configuration barcode decode	0x01	Reserved
Boot Up Event	System power-up	0x03	Yes
Parameter Event	Parameter Entry Error	0x07	Reserved
	Parameter stored	0x08	Reserved
	Default set	0x0A	Reserved
	Number expected	0x0F	Reserved

For example:

Length	Opcode	Message Source	Status	Event Code	Checksum
0x05	0xF6	0x00	0x00	0x03	0xFF 0x02

The engine sends this message when an enabled event occurs.

Host Requirements

The host receives this message when a selected event occurs.

Engine Requirements

Generate this message when a selected event occurs.

7-9 LED_OFF

Description: De-activate LED output

Packet Format

Length	Opcode	Message Source	Status	LED Selection	Checksum
0x05	0xE8	0x04		0x01	

Field Descriptions

Field Name	Format	Size	Description
Length	Length of message (not including checksum).	1 Byte	Length Field
Opcode	0xE8	1 Byte	Identifies this opcode type.
Message Source	0x04 = Host	1 Byte	Identifies where the message is coming from.
Status	Bit 0: Retransmit Bit 1-7: Unused	1 Byte	Identifies the transmission status. Unused bits must be set to 0.
LED Selection	Bit 0 - 7: LED bit numbers to turn off.	1 Byte	Bit 0 = decode LED All other bits should be set to 0.
Checksum	2's complement sum of message contents excluding checksum.	2 Bytes	Checksum of message.

The host asks the engine to turn off the decode LED.

For example:

Length	Opcode	Message Source	Status	LED Selection	Checksum
0x05	0xE8	0x04	0x00	0x01	0xFF 0x0E

Host Requirements

None.

Engine Requirements

The engine turns off the decode LED.

7-10 LED_ON

Description: Activate LED output

Packet Format

Length	Opcode	Message Source	Status	LED Selection	Checksum
0x05	0xE7	0x04		0x01	

Field Descriptions

Field Name	Format	Size	Description
Length	Length of message (not including checksum).	1 Byte	Length Field
Opcode	0xE7	1 Byte	Identifies this opcode type.
Message Source	0x04 = Host	1 Byte	Identifies where the message is coming from.
Status	Bit 0: Retransmit Bit 1-7: Unused	1 Byte	Identifies the transmission status. Unused bits must be set to 0.
LED Selection	Bit 0 - 7: LED bit numbers to turn on.	1 Byte	Bit 0 = decode LED All other bits should be set to 0.
Checksum	2's complement sum of message contents excluding checksum.	2 Bytes	Checksum of message.

The host asks the engine to turn on the decode LED.

For example:

Length	Opcode	Message Source	Status	LED Selection	Checksum
0x05	0xE7	0x04	0x00	0x01	0xFF 0x0F

Host Requirements

None.

Engine Requirements

The engine turns on the decode LED.

7-11 SE_PARAM_DEFAULTS

Description: Set the parameters to the SE serial default values

Packet Format

Length	Opcode	Message Source	Status	Checksum
0x04	0xC8	0x04		

Field Descriptions

Field Name	Format	Size	Description
Length	Length of message (not including checksum).	1 Byte	Length Field
Opcode	0xC8	1 Byte	Identifies this opcode type.
Message Source	0x04 = Host	1 Byte	Identifies where the message is coming from.
Status	Bit 0: Retransmit Bit 1-7: Unused	1 Byte	Identifies the transmission status. Unused bits must be set to 0.
Checksum	2's complement sum of message contents excluding checksum.	2 Bytes	Checksum of message.

This command returns all parameters to the SE serial default settings.

For example:

Length	Opcode	Message Source	Status	Checksum
0x04	0xC8	0x04	0x00	0xFF 0x30

Host Requirements

The host sends this command to reset the engine's parameter settings to the SE serial default values.

Engine Requirements

Upon receiving this command, the engine resets all its parameters to the factory default values. The behavior is the same as scanning **Load SE serial defaults** configuration barcode (see [13 Return default parameters & firmware version](#)).

7-12 SE_PARAM_REQUEST

Description: Request values of selected SE serial parameters

Packet Format

Length	Opcode	Message Source	Status	Request Data	Checksum
	0xC7	0x04			

Field Descriptions

Field Name	Format	Size	Description
Length	Length of message (not including checksum).	1 Byte	Length Field
Opcode	0xC7	1 Byte	Identifies this opcode type.
Message Source	0x04 = Host	1 Byte	Identifies where the message is coming from.
Status	Bit 0: Retransmit Bit 1-7: Unused	1 Byte	Identifies the transmission status. Unused bits must be set to 0.
Request Data	<Para_code><Para_code> <Para_code>...	Variable	
Checksum	2's complement sum of message contents excluding checksum.	2 Bytes	Checksum of message.

The host uses this message to request selected SE serial parameters from the engine.

Host Requirements

The host requests the engine's current values for specific parameters by listing the parameter numbers in the Request Data field. If the host asks for a parameter value which is not supported by the engine, the engine responses NAK.

The engine's response to this command is SE_PARAM_SEND, not ACK. Depending on the time-out set, and the number of parameters requested, this reply may fall outside the programmable **Host Serial Response Time-out**. If this occurs, this is not a time-out error. To compensate, increase the time-out.

Engine Requirements

When the engine receives this message, it processes the information by formatting a SE_PARAM_SEND message containing all requested parameters supported and their values. The programmable **Host Serial Response Time-out** can be exceeded when processing this message, depending on the time-out set and the number of parameters requested.

Examples:

Table 7-6 shows some parameter codes supported by the engine.

Table 7-6 Example of supported parameter code

Parameter Code	Parameter Value
0x01	0x00
0x02	0x01
0x9C	0x07
0xE6	0x63

Table 7-7 shows examples of requests and responses.

Table 7-7 Examples of requests and replies

Parameter Code	SE_PARAM_REQUEST message	SE_PARAM_SEND message in response
0x01, 0x9C	06 C7 04 00 01 9C FE 92	09 C6 00 00 FF 01 00 9C 07 FD 8E
0x04	05 C7 04 00 04 FF 2C	05 C6 00 00 FF FE 36

Unsupported parameters are not listed in the SE_PARAM_SEND response. Requesting unsupported parameters has no effect, but can cause delays in responding to requests for valid parameters.

7-13 SE_PARAM_SEND

Description: Two optional operations: 1) Respond to a SE_PARAM_REQUEST, or 2) change particular parameter values.

Packet Format

Length	Opcode	Message Source	Status	Beep Code	Para. data	Checksum
	0xC6					

Field Descriptions

Field Name	Format	Size	Description
Length	Length of message (not including checksum).	1 Byte	Length Field
Opcode	0xC6	1 Byte	Identifies this opcode type.
Message Source	0x00 = Engine 0x04=Host	1 Byte	Identifies where the message is coming from.
Status	Bit 0: Retransmit Bits 1, 2: Unused Bit 3: Change Type Bits 4-7: Unused	1 Byte	Bit 0: =1, indicates a retransmit Bit 3: =1, Permanent change =0, Temporary change, setting will be lost when power removed or when the engine enters Sleep Power state. Not recommended to frequently use. Unused bits must be set to 0.
Beep code	See Table 7-3	1 Byte	If no beep is required, set this field to 0xFF.
Param_data	See Table 7-8		The parameter numbers and data to be sent to the requester.
Checksum	2's complement sum of message contents excluding checksum.	2 Bytes	Checksum of message.

This message is sent by the engine in response to the SE_PARAM_REQUEST message, or by the host to change the engine's parameter values.

Parameter numbers 0xF0 (+256), 0xF1 (+512), 0xF2 (+768) are used to access parameters whose numbers are 256 and higher. For example, to access the first parameter in the 256-511 range, use 0xF0 and 0x00.

Table 7-8 Param_data format

Parameter Code	Data Format
0 through 0xEF	<Para_Code> <Para_value>
0xF0, 0xF1, 0xF2	<extended parameter> <Para_Code offset> <Para_value>

For example: to enable UPC-A

Length	Opcode	Message source	Status	Beep Code	Para. data	Checksum
0x07	0xC6	0x04	0x08	0x00	0x01 0x01	0xFF 0x25

Host Requirements

The host transmits this message to change the engine's parameters. Be sure the Change Type bit in the Status field is set as desired. If no beep is required, the beep code must be set to 0xFF, or the engine beeps as defined in Table 7-3.

Engine Requirements

Due to the processing time of interpreting and storing parameters contained in the message, the engine may not be able to send an ACK within the programmable Host Serial Response time-out. This is not an error; to compensate, increase the time-out.

When the engine receives a SE_PARAM_SEND, it interprets and stores the parameters, then ACKs the command (if ACK/NAK handshaking is enabled). These parameters are stored permanently only if the Change Type (bit 3 of the Status byte) is set to 1. Frequent permanent changes are not recommended due to the limited write-cycles of flash memory. If bit 3 is set to 0, the changes are temporary, and are lost when the engine is powered down or when the engine is entering SLEEP Power state.

If the SE_PARAM_SEND sent by the host contains a valid beep code (see Table 7-3 in section 7-4), the engine issues the requested beep sequence, and stores the requested parameter values.

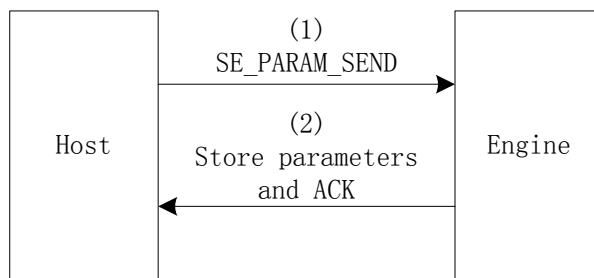

The engine issues a SE_PARAM_SEND in response to a SE_PARAM_REQUEST from the host. It responds to the SE_PARAM_REQUEST message by sending all supported parameter values. No value is sent for any unsupported parameter. If none of the requested values is supported, the SE_PARAM_SEND message is transmitted with no parameters.

When the engine is sending SE_PARAM_SEND command, the Change Type bit (bit 3 of Status byte) can be ignored.

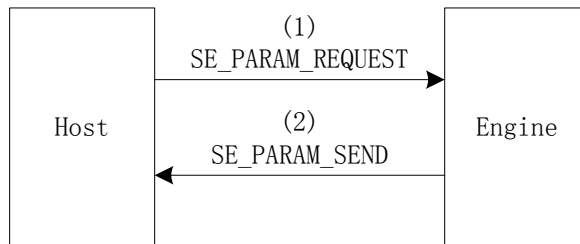

7-14 SE_CUSTOM_DEFAULTS

Description: Two optional operations: 1) Write current setting to SE Serial Custom Defaults, or 2) Set the parameters to SE serial custom default values.

Packet Format

Byte	Bit							
	7	6	5	4	3	2	1	0
0	Length = 6 (not including checksum)							
1	Opcode = 12h							
2	Message Source = 4							
3	ΔMIMIC Supported		Reserved				Retransmit	
4	Action							
5-6	Checksum							

Field Descriptions

Field Name	Description
Length	Length of message not including the checksum.
Opcode	The opcode for this message.
Message Source	Identifies the sender of the message: Host = 4
ΔMIMIC Supported	Identifies compliance to the MIMIC System Architecture.
Retransmit	Identifies if a message was resent or not. Values: 0 = First transmission 1 = Subsequent transmission
Action	Identifies the operation to perform on the custom defaults buffer. Values: 0 = Write to SE Serial Custom Defaults 1 = Restore SE Serial Custom Defaults
Checksum	16 bit twos complements checksum of message (two byte field size).

For example:

Write to SE Serial Custom Defaults: 0x05 0x12 0x04 0x00 0x00 0xFF 0xE5

Restore SE Serial Custom Defaults: 0x05 0x12 0x04 0x00 0x01 0xFF 0xE4

Host Requirements

The host sends this command to program or restore the custom default parameter values.

Engine Requirements

Upon receiving this command, the engine writes/stores the current parameter settings to the custom defaults buffer. They can be recovered at any time by sending a restore action.

If the restore action is requested, reset all default parameters as follows:

✚ If custom defaults were set by sending **Write to SE Serial Custom Defaults** command, send **Restore**

SE Serial Custom Defaults command to retrieve and restore the scan engine custom default settings.

- ✚ If no custom defaults were set, send **Restore SE Serial Custom Defaults** to restore the factory default values as SE serial defaults.

7-15 REQUEST_REVISION

Description: Request the software revision string from the engine

Packet Format

Length	Opcode	Message Source	Status	Checksum
0x04	0xA3	0x04		

Field Descriptions

Field Name	Format	Size	Description
Length	Length of message (not including checksum).	1 Byte	Length Field
Opcode	0xA3	1 Byte	Identifies this opcode type.
Message Source	0x04 = Host	1 Byte	Identifies where the message is coming from.
Status	Bit 0: Retransmit Bits 1-7: Unused	1 Byte	Identifies the transmission status. Unused bits must be set to 0.
Checksum	2's complement sum of message contents excluding checksum.	2 Bytes	Checksum of message.

For example:

Length	Opcode	Message Source	Status	Checksum
0x04	0xA3	0x04	0x00	0xFF 0x55

Host Requirements

The host sends this message to request revision information from the engine. The engine responds with REPLY_REVISION.

Engine Requirements

The engine sends its revision string to the host. See REPLY_REVISION for format.

7-16 REPLY_REVISION

Description: Reply to REQUEST_REVISION command with software revision string

Packet Format

Length	Opcode	Message Source	Status	Revision	Checksum
	0xA4	0x00			

Field Descriptions

Field Name	Format	Size	Description
Length	Length of message (not including checksum).	1 Byte	Length Field
Opcode	0xA4	1 Byte	Identifies this opcode type.
Message Source	0x00 = Engine	1 Byte	Identifies where the message is coming from.
Status	Bit 0: Retransmit Bits 1-7: Unused	1 Byte	Identifies the transmission status. Unused bits must be set to 0.
Revision	ASCII data	variable	Software revision in ASCII (* see following for details).
Checksum	2's complement sum of message contents excluding checksum.	2 Bytes	Checksum of message.

Host Requirements

None.

Engine Requirements

*The engine sends its Revision field data string to the host in the following format:

HW/SW_REVISION<space>BOARD_TYPE<space>SCANNER_ID<space> REVISION_CHKSUM

Where:

HW/SW_RIVISION is the version string including hardware and software information.

BOARD_TYPE is 'F'.

ENGINE_ID is always 0xAB for uE serial.

REVISION_CHKSUM is a two-byte checksum. It's the 2's complement sum of the Revision contents excluding REVISION_CHKSUM.

For example, if the HW/SW_REVISION is "uE966_HW3.x_SW2.2.11", the REPLY_REVISION message will be:

Length	Opcode	Message Source	Status	Revision	Checksum
0x1F	0xA4	0x00	0x00	0x75 0x45 0x39 0x36 0x36 0x5F 0x48 0x57 0x33 0x2E 0x78 0x5F 0x53 0x57 0x32 0x2E 0x32 0x2E 0x31 0x31 0x20 0x46 0x20 0xAB 0x20 0xF9 0x4E	0xF7 0x44

7-17 SCAN_DISABLE

Description: Prevent the engine from scanning barcodes

Packet Format

Length	Opcode	Message Source	Status	Checksum
0x04	0xEA	0x04		

Field Descriptions

Field Name	Format	Size	Description
Length	Length of message (not including checksum).	1 Byte	Length Field
Opcode	0xEA	1 Byte	Identifies this opcode type.
Message Source	0x04 = Host	1 Byte	Identifies where the message is coming from.
Status	Bit 0: Retransmit Bits 1-7: Unused	1 Byte	Identifies the transmission status. Unused bits must be set to 0.
Checksum	2's complement sum of message contents excluding checksum.	2 Bytes	Checksum of message.

For example:

Length	Opcode	Message Source	Status	Checksum
0x04	0xEA	0x04	0x00	0xFF 0x0E

Host Requirements

All scan attempts are disabled by this command until either a SCAN_ENABLE is sent, or the engine is reset.

Engine Requirements

When the engine receives this command, it ignores all trigger/START_DECODE requests until a SCAN_ENABLE command is received, or the engine is reset.

7-18 SCAN_ENABLE

Description: Permit the engine to scan barcodes

Packet Format

Length	Opcode	Message Source	Status	Checksum
0x04	0xE9	0x04		

Field Descriptions

Field Name	Format	Size	Description
Length	Length of message (not including checksum).	1 Byte	Length Field
Opcode	0xE9	1 Byte	Identifies this opcode type.
Message Source	0x04 = Host	1 Byte	Identifies where the message is coming from.
Status	Bit 0: Retransmit Bits 1-7: Unused	1 Byte	Identifies the transmission status. Unused bits must be set to 0.
Checksum	2's complement sum of message contents excluding checksum.	2 Bytes	Checksum of message.

For example:

Length	Opcode	Message Source	Status	Checksum
0x04	0xE9	0x04	0x00	0xFF 0x0F

Host Requirements

The host sends the SCAN_ENABLE command to enable the permission of barcode scanning. Scanning is enabled upon power-up, so this command is only sent if a prior SCAN_DISABLE command has been sent.

Engine Requirements

The engine allows scanning and decoding upon receipt of this command.

✚ At initial power-up, the engine assumes SCAN_ENABLED.

7-19 START_DECODE

Description: Ask the engine to attempt to decode a barcode

Packet Format

Length	Opcode	Message Source	Status	Checksum
0x04	0xE4	0x04		

Field Descriptions

Field Name	Format	Size	Description
Length	Length of message (not including checksum).	1 Byte	Length Field
Opcode	0xE4	1 Byte	Identifies this opcode type.
Message Source	0x04 = Host	1 Byte	Identifies where the message is coming from.
Status	Bit 0: Retransmit Bits 1-7: Unused	1 Byte	Identifies the transmission status. Unused bits must be set to 0.
Checksum	2's complement sum of message contents excluding checksum.	2 Bytes	Checksum of message.

This command asks the engine to start a scan and a decode session. The decode session ends with a successful decode, or a scan session time-out, or a STOP_DECODE command.

For example:

Length	Opcode	Message Source	Status	Checksum
0x04	0xE4	0x04	0x00	0xFF 0x14

Host Requirements

None.

Engine Requirements

The Trigger mode parameter (see [6-4 Trigger mode & some global settings](#)) must be set Host.

7-20 STOP_DECODE

Description: Ask engine to abort a decode attempt

Packet Format

Length	Opcode	Message Source	Status	Checksum
0x04	0xE5	0x04		

Field Descriptions

Field Name	Format	Size	Description
Length	Length of message (not including checksum).	1 Byte	Length Field
Opcode	0xE5	1 Byte	Identifies this opcode type.
Message Source	0x04 = Host	1 Byte	Identifies where the message comes from.
Status	Bit 0: Retransmit Bits 1-7: Unused	1 Byte	Identifies the transmission status. Unused bits must be set to 0.
Checksum	2's complement sum of message contents excluding checksum.	2 Bytes	Checksum of message.

This command asks the engine to stop a scan and a decode attempt.

For example:

Length	Opcode	Message Source	Status	Checksum
0x04	0xE5	0x04	0x00	0xFF 0x13

Host Requirements

None.

Engine Requirements

The Trigger mode parameter (see [6-4 Trigger mode & some global settings](#)) must be set Host.

7-21 SLEEP

Description: Request to place the engine into Sleep Power state

Packet Format

Length	Opcode	Message Source	Status	Checksum
0x04	0xEB	0x04		

Field Descriptions

Field Name	Format	Size	Description
Length	Length of message (not including checksum).	1 Byte	Length Field
Opcode	0xEB	1 Byte	Identifies this opcode type.
Message Source	0x04 = Host	1 Byte	Identifies where the message is coming from.
Status	Bit 0: Retransmit Bits 1-7: Unused	1 Byte	Identifies the transmission status. Unused bits must be set to 0.
Checksum	2's complement sum of message contents excluding checksum.	2 Bytes	Checksum of message.

For example:

Length	Opcode	Message Source	Status	Checksum
0x04	0xEB	0x04	0x00	0xFF 0x0D

Host Requirements

The host sends this command to place the engine into Sleep Power state.

Engine Requirements

If the Low Power mode parameter is enabled, the engine goes into Sleep Power state automatically, and the SLEEP command is not necessary.

The engine will not sleep immediately upon acknowledging the command if it is processing data when the SLEEP command is sent.

7-22 WAKEUP

Description: Wakeup engine after it's been put into Sleep Power state

Command format: Null (0x00)

If the engine is in Sleep Power state, sending the single character Null (0x00) wakes up the engine. This character is only needed when hardware handshaking is not used or is bypassed.

Host Requirements

Once the WAKEUP command is sent, the host must wait at least 20 ms, but less than 1 second before sending additional data, since the engine is required to wait 1 second after waking up before going back to sleep (if Low Power mode is enabled).

Engine Requirements

The engine must not return to Sleep Power state for at least 1 second after waking up.

✚ The mechanism to wake up an engine in this manner also works if characters other than WAKEUP are sent to the engine. There is, however, no guarantee that these commands are interpreted correctly upon power-up. Therefore, it is not recommended that characters other than WAKEUP be used to awaken the engine.

The WAKEUP command has no effect if the engine is in AWAKE Power state. If the host is unsure of the engine power state, it can send the WAKEUP command anytime it wants to communicate with the engine, and waits at least 20 ms then sends any command.

Note: The related number of Null associated with baud rate is shown as below.

Baud rate	Related number of Null (0x00)
1200	2
2400	2
4800	2
9600	3
19200	6
38400	9

7-23 UE_PARAM_DEFAULTS

Description: Set the parameters to uE serial default values

Packet Format

Length	Opcode	Message Source	Status	Checksum
0x04	0xD8	0x04		

Field Descriptions

Field Name	Format	Size	Description
Length	Length of message (not including checksum).	1 Byte	Length Field
Opcode	0xD8	1 Byte	Identifies this opcode type.
Message Source	0x04 = Host	1 Byte	Identifies where the message is coming from.
Status	Bit 0: Retransmit Bit 1-7: Unused	1 Byte	Identifies the transmission status. Unused bits must be set to 0.
Checksum	2's complement sum of message contents excluding checksum.	2 Bytes	Checksum of message.

This command returns all parameters to their factory default settings.

For example:

Length	Opcode	Message Source	Status	Checksum
0x04	0xD8	0x04	0x00	0xFF 0x20

Host Requirements

The host sends this command to reset the engine's parameter settings to the factory uE serial default values.

Engine Requirements

Upon receiving this command, the engine resets all its parameters to the factory default values. The behavior is the same as scanning **Load uE serial defaults** configuration barcode (see [13 Return default parameters & firmware version](#)).

7-24 UE_PARAM_REQUEST

Description: Request values of selected uE serial parameters

Packet Format

Length	Opcode	Message Source	Status	Request Data	Checksum
	0xD7	0x04			

Field Descriptions

Field Name	Format	Size	Description
Length	Length of message (not including checksum).	1 Byte	Length Field
Opcode	0xD7	1 Byte	Identifies this opcode type.
Message Source	0x04 = Host	1 Byte	Identifies where the message is coming from.
Status	Bit 0: Retransmit Bit 1-7: Unused	1 Byte	Identifies the transmission status. Unused bits must be set to 0.
Request Data	<Para_code_HighByte><Para_code_LowByte> <Para_code_HighByte><Para_code_LowByte> ...	Variable	Each uE parameter code has two bytes.
Checksum	2's complement sum of message contents excluding checksum.	2 Bytes	Checksum of message.

The host uses this message to request selected uE serial parameters from the engine.

Host Requirements

The host requests the engine's current values for specific parameters by listing the parameter codes in the Request Data field. If the host asks for a parameter value which is not supported by the engine, the engine responses NAK.

The engine's response to this command is UE_PARAM_SEND, not ACK. Depending on the time-out setting, and the number of parameters requested, this reply may fall outside the programmable **Host Serial Response Time-out**. If this occurs, this is not a time-out error. To compensate, increase the time-out.

Engine Requirements

When the engine receives this message, it processes the information by formatting a UE_PARAM_SEND message containing all requested parameters supported and their values. The programmable **Host Serial Response Time-out** can be exceeded when processing this message, depending on the time-out set and the number of parameters requested.

Examples:

Table 7-9 shows examples of requests and responses.

Table 7-9 Examples of requests and replies

Parameter code	Value	UE_PARAM_REQUEST	UE_PARAM_SEND message in response
0301 (0x012D)	01	06 D7 04 00 01 2D FE F1	09 D6 00 00 FF 01 2D 01 01 FD F2
0302 (0x012E)	00	08 D7 04 00 01 2E 01 2F FE BE	0D D6 00 00 FF 01 2E 01 00 01 2F 01 00 FD
0303 (0x012F)	00		BD
0301 (0x012D)	01	0A D7 04 00 01 2D 01 2E 01 2F FE 8E	11 D6 00 00 FF 01 2D 01 01 01 2E 01 00 01
0302 (0x012E)	00		2F 01 00 FD 89
0303 (0x012F)	00		

7-25 UE_PARAM_SEND

Description: Two optional operations: 1) Respond to a UE_PARAM_REQUEST, or 2) change particular parameter values.

Packet Format

Length	Opcode	Message source	Status	Beep code	Para. code	Value length	Para. value	Checksum
	0XD6							

Field Descriptions

Field Name	Format	Size	Description
Length	Length of message (not including checksum).	1 Byte	Length Field
Opcode	0xD6	1 Byte	Identifies this opcode type.
Message Source	0x00 = Engine 0x04=Host	1 Byte	Identifies where the message is coming from.
Status	Bit 0: Retransmit Bits 1, 2: Unused Bit 3: Change Type Bits 4-7: Unused	1 Byte	Bit 0: 1 indicates a retransmit Bit 3: =1, Permanent change =0, Temporary change – setting will be lost when power removed or when the engine enters Sleep Power state. Not recommended to frequently use. Unused bits must be set to 0.
Beep code	See Table 7-3.	1 Byte	If no beep is required, set this field to 0xFF.
Para_Code	<Para_Code_HighByte> <Para_Code_LowByte>	2 Bytes	Each uE parameter code has two byte.
Para_Value_Len		Variable	The counter of the Parameter value.
Para_Value		Variable	
Checksum	2's complement sum of message contents excluding checksum.	2 Bytes	Checksum of message.

This message is sent by the engine in response to the UE_PARAM_REQUEST message, or by the host to change the engine's parameter values.

Example: to set parameter Flow control to be **None** (see [6-3 UART interface](#)).

Length	Opcode	Message source	Status	Beep code	Para. code	Value length	Para. value	Checksum
0x09	0XD6	0x04	0x08	0x01	0x01 0x2D	0x01	0x00	0xFE 0xE5

More examples are shown as follows.

Table 7-10 Examples of changing parameters by UE_PARAM_SEND

Para. code	UE_PARAM_SEND message	Para. value to be
0301(0X012D)	09 D6 04 08 01 01 2D 01 01 FE E4	01
0301(0X012D)	11 D6 04 08 01 01 2D 01 01 01 2E 01 01 01 2F 01 03 FE 77	01
0302(0X012E)		01
0304(0X012F)		03
8001(0X1F41)	0B D6 04 08 01 1F 41 03 31 32 33 FE 19	31, 32, 33

Host Requirements

The host transmits this message to change the engine’s parameters. Be sure the Change Type bit in the Status field is set as desired. If no beep is required, the beep code must be set to 0xFF, or the engine beeps as defined in Table 7-3.

Engine Requirements

- ✚ Due to the processing time of interpreting and storing parameters contained in the message, the engine may not be able to send an ACK within the programmable Host Serial Response time-out. This is not an error; to compensate, increase the time-out.
 - ✚ When the engine receives a UE_PARAM_SEND, it interprets and stores the parameters, then ACKs the command (if ACK/NAK handshaking is enabled). These parameters are stored permanently only if the Change Type (bit 3 of the Status byte) is set to 1. Frequent permanent changes are not recommended due to the limited write-cycles of flash memory. If bit 3 is set to 0 the changes are temporary, and are lost when the engine is powered down.
- If the UE_PARAM_SEND sent by the host contains a valid beep code (see Table 7-3 in section 7-4), the engine issues the requested beep sequence and stores the requested parameter values.

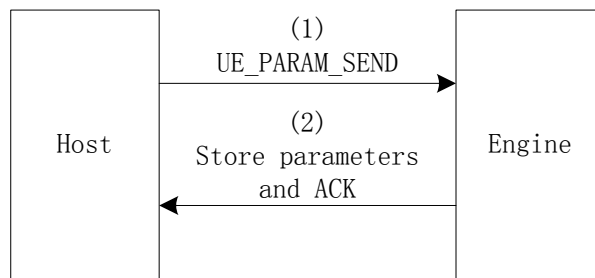

- ✚ The engine issues a UE_PARAM_SEND in response to a UE_PARAM_REQUEST from the host. It responds to the UE_PARAM_REQUEST message by sending all supported parameter values. No value is sent for any unsupported parameter. If none of the requested values is supported, the UE_PARAM_SEND message is transmitted with no parameters. When sending this command, the Change Type bit (bit 3 of Status byte) can be ignored.

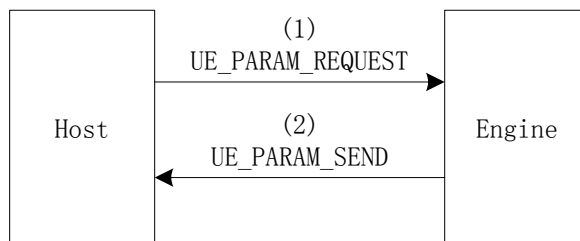

7-26 UE_CUSTOM_DEFAULTS

Description: Two optional operations: 1) Write current setting to SE Serial Custom Defaults, or 2) Set the parameters to SE serial custom default values.

Packet Format

Byte	Bit							
	7	6	5	4	3	2	1	0
0	Length = 6 (not including checksum)							
1	Opcode = 0x22							
2	Message Source = 4							
3	ΔMIMIC Supported		Reserved				Retransmit	
4	Action							
5-6	Checksum							

Field Descriptions

Field Name	Description
Length	Length of message not including the checksum.
Op-code	The Op-code for this message.
Message Source	Identifies the sender of the message: Host = 4
ΔMIMIC Supported	Identifies compliance to the MIMIC System Architecture.
Retransmit	Identifies if a message was resent or not. Values: 0 = First transmission 1 = Subsequent transmission
Action	Identifies the operation to perform on the custom defaults buffer. Values: 0 = Write to uE Serial Custom Defaults 1 = Restore uE Serial Custom Defaults
Checksum	16 bit twos complements checksum of message (two byte field size).

For example:

Write to uE Serial Custom Defaults: 0x05 0x22 0x04 0x00 0x00 0xFF 0xD5

Restore uE Serial Custom Defaults: 0x05 0x22 0x04 0x00 0x01 0xFF 0xD4

Host Requirements

The host sends this command to program or restore the custom default values.

Decoder Requirements

Upon receiving this command, the scan engine writes/stores the current parameter settings to the custom defaults buffer. They can be recovered at any time by sending a restore action.

If the restore action is requested, reset all default parameters as follows:

✚ If custom defaults were set by sending **Write to uE Serial Custom Defaults**, send **Restore uE Serial**

Custom Defaults to retrieve and restore the scan engine custom default settings.

- ✚ If no custom defaults were set, send **Restore uE Serial Custom Defaults** to restore the factory default values as uE serial defaults.

7-27 MANUFACTURE_INFO_REQUEST

Description: Request information of manufacture

Packet Format

Length	Opcode	Message Source	Status	Manu. Info. Index	Checksum
0x05	0xB7	0x04			

Field Descriptions

Field Name	Format	Size	Description
Length	Length of message (not including checksum).	1 Byte	Length Field
Opcode	0xB7	1 Byte	Identifies this opcode type.
Message Source	0x04 = Host	1 Byte	Identifies where the message is coming from.
Status	Bit 0: Retransmit Bit 1-7: Unused	1 Byte	Identifies the transmission status. Unused bits must be set to 0.
Manu. Info. Index	Manufacture information Index	1 Byte	0x00: Serial number 0x01: Manufacture Date 0x02-0x08: Reserved Others: Not allowed.
Checksum	2's complement sum of message contents excluding checksum.	2 Bytes	Checksum of message.

The host uses this message to request selected information of manufacture from the engine.

Host Requirements

The host requests the engine's specific manufacture information in the Request Data field. If the host asks for the manufacture information which is not supported by the engine, the engine responses NAK.

The engine's response to this command is MANUFACTURE_INFO_SEND, not ACK.

Engine Requirements

When the engine receives this message, it processes the information by formatting a MANUFACTURE_INFO_SEND message.

Table 7-7 shows examples of requests and responses.

Table 7-11 Examples of requests and replies

Manufacture information Index	MANUFACTURE_INFO_REQUEST message	MANUFACTURE_INFO_SEND message in response
0x00	0x05 0xB7 0x04 0x00 0x00 0xFF 0x40	0x10 0xB6 0x00 0x00 0x00 0x4F 0x41 0x30 0x31 0x30 0x30 0x30 0x34 0x39 0x32 0x00 0xFD 0x1A
0x01	0x05 0xB7 0x04 0x00 0x01 0xFF 0x3F	0x0F 0xB6 0x00 0x00 0x01 0x30 0x35 0x44 0x45 0x43 30x2 0x30 0x31 0x33 0x00 0xFD 0x43

Note: The engine's SN is **OA1000492** and is manufactured on **05 DEC in 2013**.

7-28 MANUFACTURE_INFO_SEND

Description: Respond to a MANUFACTURE_INFO_REQUEST

Packet Format

Length	Opcode	Message Source	Status	Manu. Info. Index	Manu. Info. data	Checksum
	0xB6	0x00				

Field Descriptions

Field Name	Format	Size	Description
Length	Length of message (not including checksum).	1 Byte	Length Field
Opcode	0xB6	1 Byte	Identifies this opcode type.
Message Source	0x00 = Engine	1 Byte	Identifies where the message is coming from.
Status	Bit 0: Retransmit Bits 1-7: Unused	1 Byte	Bit 0: Identifies the transmission status. Unused bits must be set to 0.
Manu. Info. Index	Manufacture information index	1 Byte	0x00: Serial number 0x01: Manufacture date 0x02-0x08: Reserved Others: Not allowed.
Manu. Info. data	Manufacture information content	<16 Bytes	ASCII string, ended with '\0'.
Checksum	2's complement sum of message contents excluding checksum.	2 Bytes	Checksum of message.

This message is sent by the engine in response to the MANUFACTURE_INFO_REQUEST message.

Example:

1) Engine responses serial number ("OA01000492")

Length	Opcode	Message Source	Status	Manu. Info. Index	Manu. Info. data	Checksum
0x10	0xB6	0x00	0x00	0x00	0x4F 0x41 0x30 0x31 0x30 0x30 0x30 0x34 0x39 0x32 0x00	0xFD 0x1A

2) Engine responses manufacture date ("05DEC2013")

Length	Opcode	Message Source	Status	Manu. Info. Index	Manu. Info. data	Checksum
0F	0xB6	0x00	0x00	0x01	0x30 0x35 0x44 0x45 0x43 0x32 0x30 0x31 0x33 0x00	0xFD 0x43

Host Requirements

None.

Engine Requirements

When the engine receives MANUFACTURE_INFO_REQUEST command, it processes the information of manufacture.

8 SCI transactions

8-1 ACK/NAK handshaking

If ACK/NAK handshaking is enabled, all packeted messages must have a CMD_ACK or CMD_NAK response, unless the command description states otherwise. This parameter is enabled by default, and should remain enabled to provide feedback to the host. Raw decode data and WAKEUP command do not use ACK/NAK handshaking since they are not packeted data.

- ✚ Following is an example of a problem that can occur when ACK/NAK handshaking is disabled:
 - A.1. The host sends a SE_PARAM_SEND (or UE_PARAM_SEND) message to the engine to change the baud rate from 9600 to 115200.
 - A.2. The engine cannot interpret the message.
 - A.3. The engine does not implement the changes requested by the host.
 - A.4. The host assumes that the parameter changes have occurred and acts accordingly (i.e. applying the new baud rate at 115200).
 - A.5. Communications are lost because the change did not occur on both sides, since the baud rate for engine is 9600 and the baud rate for the host is 115200.
- ✚ However, if the ACK/NAK handshaking is enabled, the following occurs:
 - B.1. The host sends a SE_PARAM_SEND (or UE_PARAM_SEND) message to the engine to change the baud rate from 9600 to 115200.
 - B.2. The engine cannot interpret the message.
 - B.3. The engine CMD_NAKs the message.
 - B.4. The host resends the message.
 - B.5. The engine receives the message successfully, responds with CMD_ACK, and implements parameter changes.

8-2 Transfer of decode data

The SE serial parameter of **Decode Data Packet Format** (see [Table 6-1 SE serial standard parameters](#)) controls how decode data is sent to the host. When this parameter is set as **Packeted**, the data is sent in a DECODE_DATA packet. When the parameter is set as **Raw**, the data is transmitted as raw ASCII data.

When decode data is transmitted as raw ASCII data, ACK/NAK handshaking does not apply regardless of the state of the ACK/NAK handshaking parameter.

a) ACK/NAK = Enabled, **Decode Data Packet Format** = Packeted

The engine sends a DECODE_DATA packet message after a successful decode. The engine waits for a programmable time-out for a CMD_ACK response. If it does not receive the response, the engine tries to send twice more before issuing a host transmission error.

If the engine receives a CMD_NAK from the host, it may attempt a retry depending on the cause field of the CMD_NAK message.

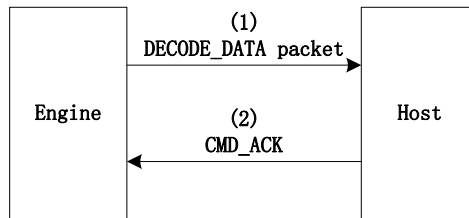

b) ACK/NAK = Enabled, **Decode Data Packet Format** = Raw

Even though the ACK/NAK handshaking is enabled, no handshaking occurs because the handshaking applies only to packet data.

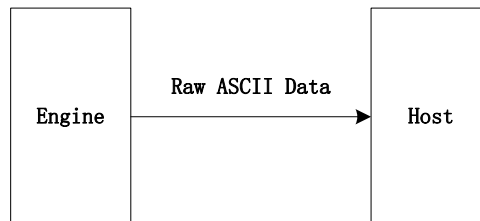

c) ACK/NAK = Disabled, **Decode Data Packet Format** = Packeted

In this example ACK/NAK does not occur because the ACK/NAK handshaking parameter is disabled.

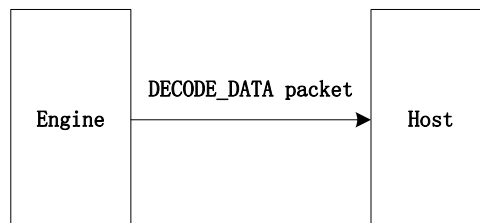

d) ACK/NAK = Disabled, **Decode Data Packet Format** = Raw

Data is captured.

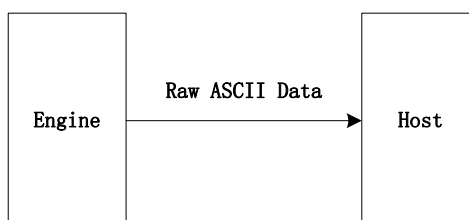

8-3 Transaction examples

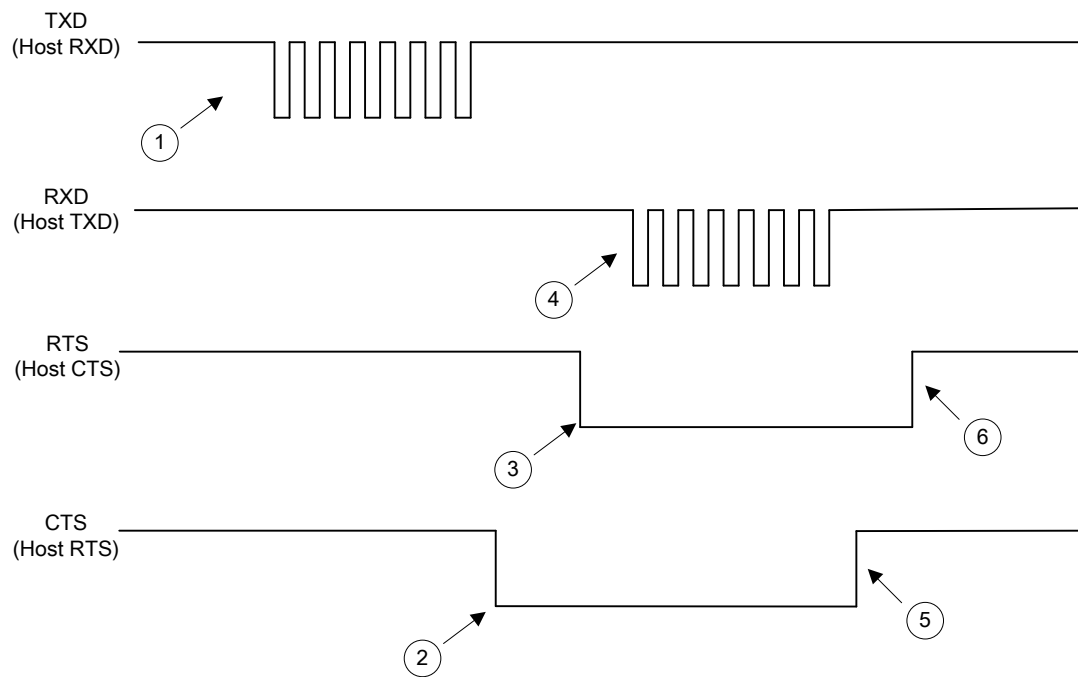

1. Engine transmits data
2. Host requests to send
3. Engine grants permission
4. Host sends an ACK
5. Host removes request
6. Engine removes permission

Figure 8-1 Basic engine initiated transaction

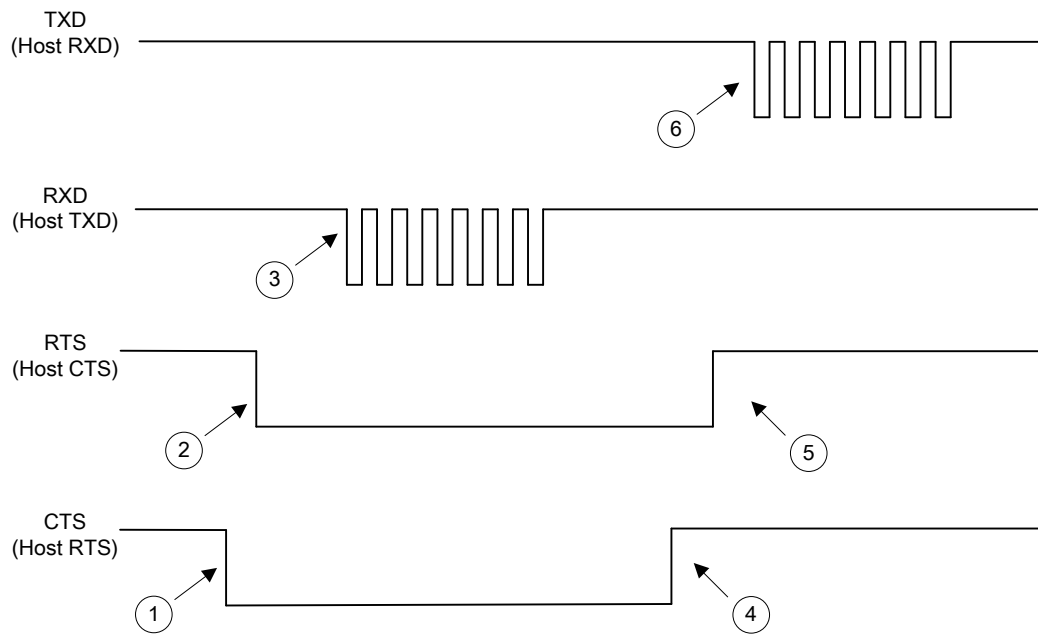

1. Host requests to send
2. Engine grants permission
3. Host sends a BEEP command
4. Host removes request
5. Engine removes permission
6. Engine sends an ACK

Figure 8-2 Basic host initiated transaction

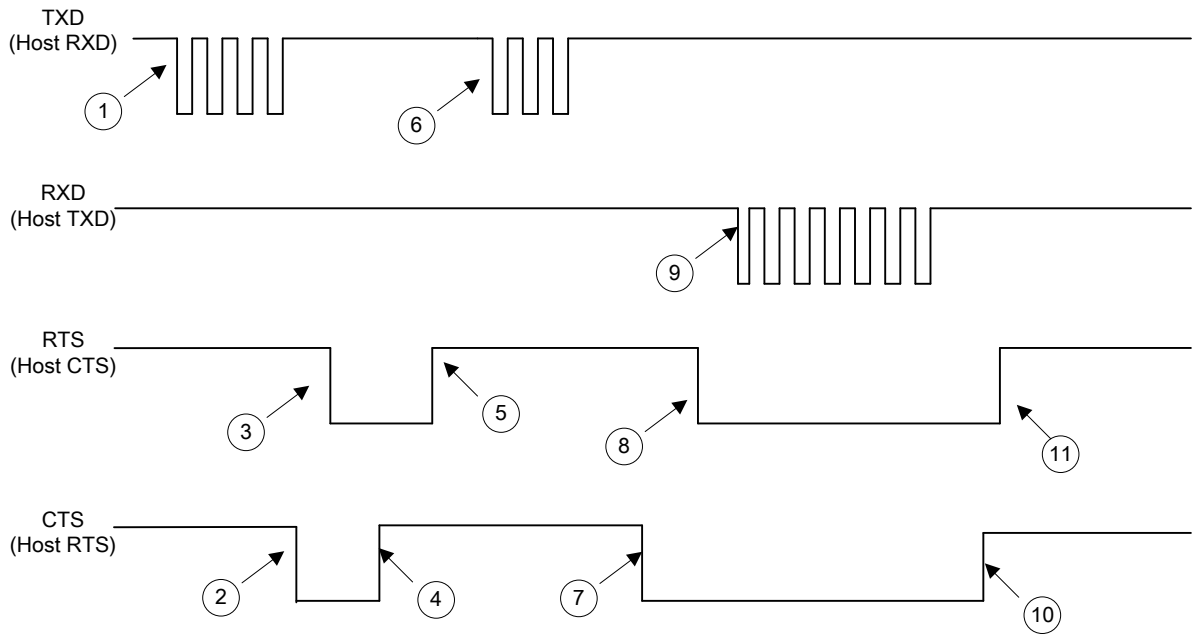

1. Engine starts to transmit
2. Host asserts RTS causing transmission pause
3. Engine grants permission for host to send
4. Host removes request without sending
5. Engine removes permission
6. Engine resumes transmission
7. Host requests permission to send an ACK
8. Engine grants permission
9. Host sends an ACK
10. Host removes request when finished sending
11. Engine removes permission

Figure 8-3 Host interrupting engine's transmission

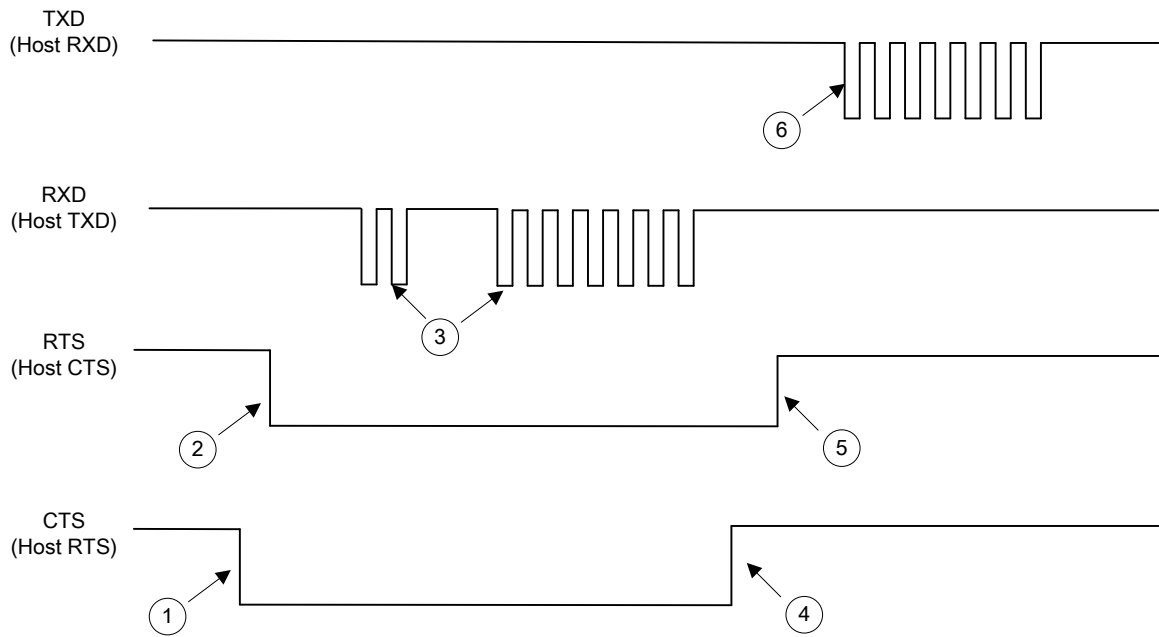

1. Host requests permission to send
2. Engine grants permission
3. Host sends 3 nulls, then a BEEP command
4. Host removes request when sending is finished
5. Engine removes permission
6. Engine sends an ACK

Figure 8-4 Host initiated transmission with leading nulls

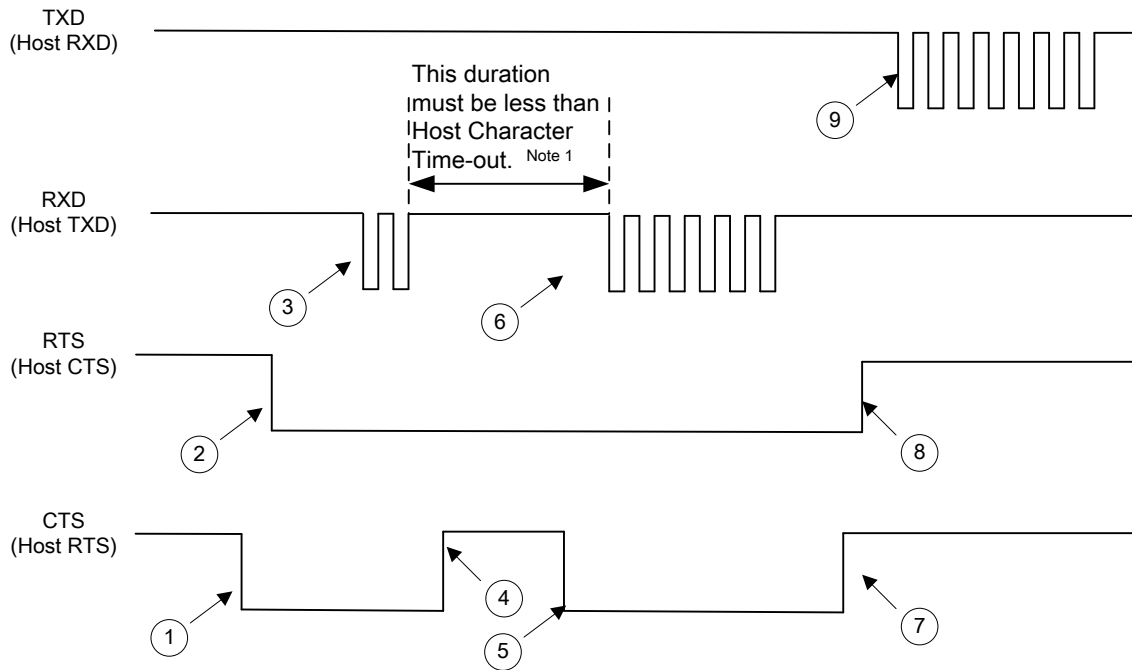

Note 1: The SE serial parameter of Host Character Time-out determines the maximum time the engine waits between characters transmitted by the host before discarding the received data and declaring an error. The default value is 200 ms.

1. Host requests permission to send
2. Engine grants permission
3. Host sends 1/2 BEEP command
4. Host removes request (ignored by engine until transmission is completed or timed out)
5. Host requests again (ignored by engine until transmission is completed or timed out)
6. Host sends remainder of BEEP command
7. Host removes request
8. Engine removes permission
9. Engine send an ACK

Figure 8-5 Host initiated transaction with varying CTS during transmission

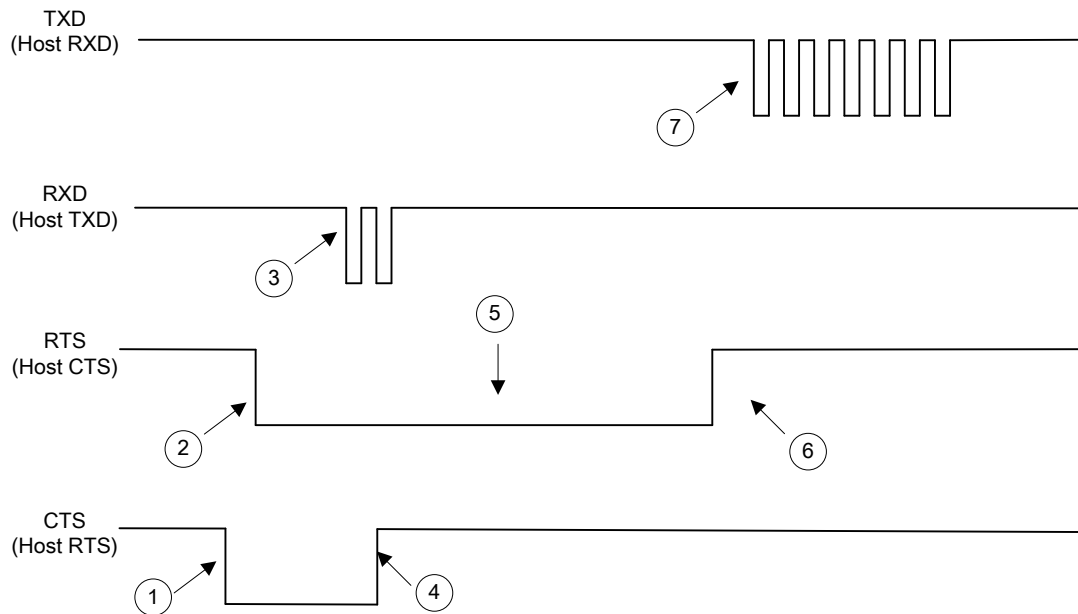

1. Host requests permission to send
2. Engine grants permission
3. Host sends 2 characters of command
4. Host removes request
5. RTS remains Low because engine is still expecting data
6. Engine times out waiting for a character and removes permission
7. Engine sends a NAK to require resending data

Figure 8-6 Error transmission: Host sends only the first 2 characters of a 6-character command

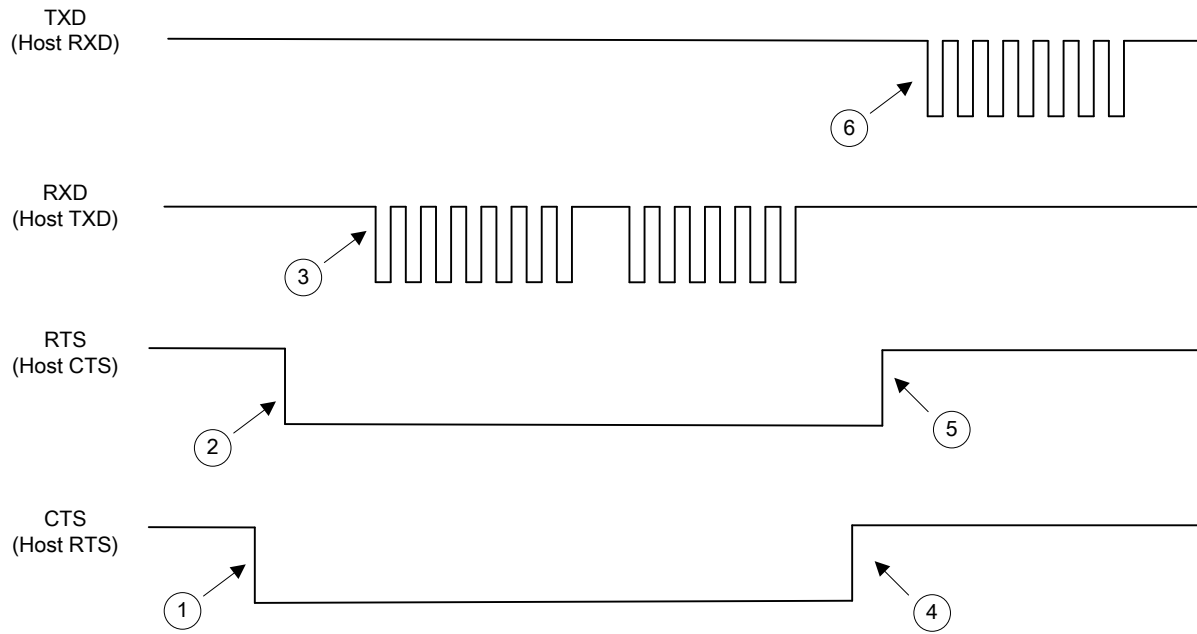

1. Host requests permission to send
2. Engine grants permission
3. Host sends 2 BEEP commands instead of 1
4. Host removes request
5. Engine removes permission
6. Engine ACKs the first BEEP command

Figure 8-7 Error condition: Host sends 2 valid BEEP commands back to back

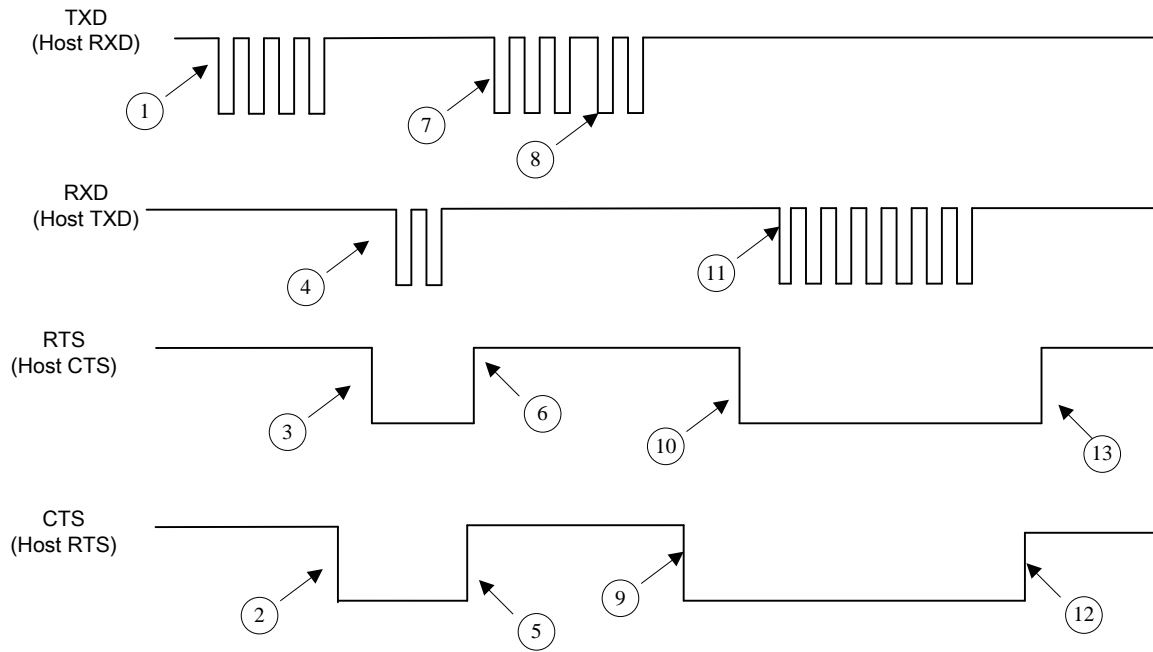

1. Engine starts to transmit
2. Host requests permission
3. Engine grants permission
4. Host causes engine's transmission aborted by sending BEEP
5. Host removes request
6. Engine removes permission
7. Engine sends an ACK
8. Engine resends data
9. Host requests permission
10. Engine grants permission
11. Host sends an ACK
12. Host removes request
13. Engine removes permission

Figure 8-8 Host causes engine to abort transmission

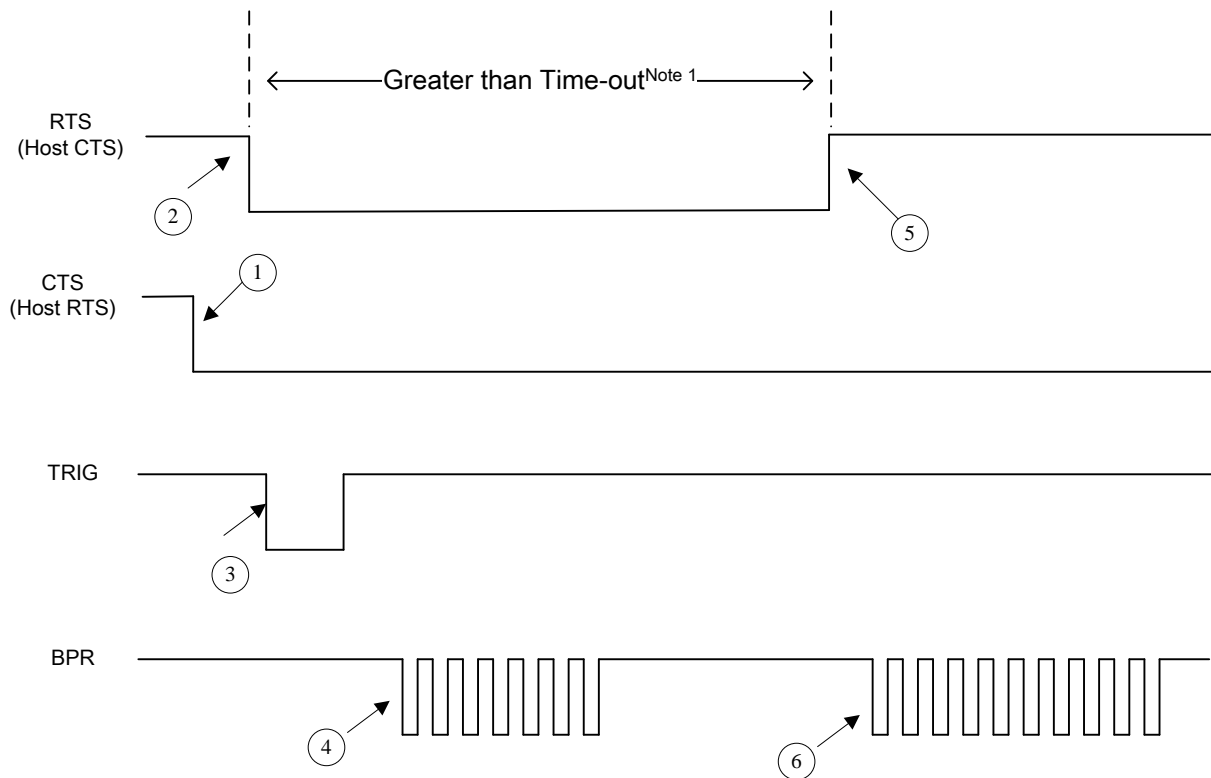

Note 1: The value of Time-out is equal to 3 times of the value of the SE serial parameter Host Serial Response Time-out (default value = 2 seconds). Thus the value of Time-out is 6 seconds.

1. Host requests permission to send
2. Engine grants permission
3. User pull down the Trigger to start decode
4. Beep after succeeding in decoding the barcode
5. Time out, engine removes request
6. Beep after failed to transmit decode data

Figure 8-9 Host prohibits engine to transmit

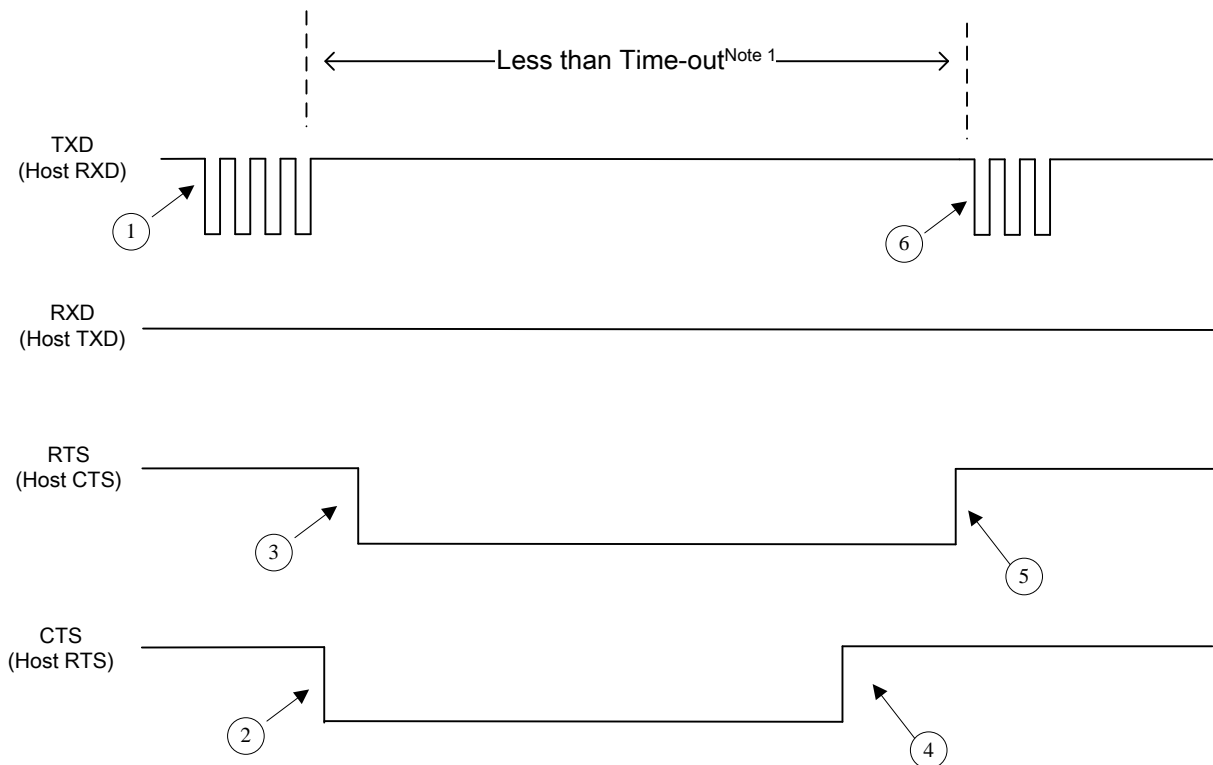

Note 1: The value of Time-out is equal to the value of the SE serial parameter Host Serial Response Time-out (default value = 2 seconds). Thus the value of Time-out is 2 seconds.

1. Engine starts to transmit
2. Host asserts RTS causing transmission pause
3. Engine grants permission for host to send
4. Host removes request without sending
5. Engine removes permission
6. Engine resumes transmission

Figure 8-10 Host pauses engine to transmit

8-4 SCI transactions notes

a) RTS/CTS Lines

It is strongly recommended that all transactions use RTS/CTS handshaking.

b) ACK/NAK Option

ACK/NAK handshaking can be enabled or disabled. This handshaking is enabled by default; disabling this is not recommended as it can lead to communication problems, since handshaking is the only indication that a message was received and if it was received correctly. ACK/NAK is not used with unpacked decode data regardless of whether or not this option is enabled.

c) Number of Data Bits

All communication with the engine must use eight bit data.

d) Host Serial Response Time-out

The Host Serial Response Time-out parameter determines how long to wait for a handshaking response before trying again, or aborting any further attempts. Both the host and engine should apply the same parameter value during communication.

A temporary change may be made to the Host Serial Response Time-out when the host takes longer to process an ACK, or longer data string. Frequent permanent changes are not recommended due to the limited write-cycles of flash memory.

e) Retries

When sending data, the host should resend twice after the initial send if the engine does not respond with an ACK or NAK (if ACK/NAK handshaking is enabled), or response data (e.g., UE_PARAM_SEND, SE_PARAM_SEND, REPLY_REVISION). If the engine replies with a NAK_RESEND message (see [7-6 CMD_NAK](#)), the host resends the data. All resent messages must set Status byte to Resend.

The engine resends data two times after the initial send if the host fails to reply with an ACK or NAK (if ACK/NAK handshaking is enabled).

f) Baud Rate, Stop Bits, Parity, Response Time-out, ACK/NAK Handshake

If the serial parameters above are changed using UE_PARAM_SEND (or SE_PARAM_SEND), the ACK response to the UE_PARAM_SEND (or SE_PARAM_SEND) uses the previous values for these parameters. The new values then take effect for the subsequent transaction.

g) Errors

The engine generates a communication error when:

1. The CTS line is asserted when the engine tries to transmit, and is still asserted on each of 2 successive retries.
2. Or failed to receive an ACK or NAK after initial transmit and two resends.

h) SCI Communication Notes

If hardware handshaking is not used, messages should be spaced sufficiently apart, and the host must not communicate with the engine when the engine is sending.

If hardware handshaking is used, frame each message properly with the handshaking signals. Do not try to send two commands within the same handshaking frame.

There is a permanent/temporary bit in the UE_PARAM_SEND (or SE_PARAM_SEND) message. Temporary changes are lost when power is removed from the engine or when the engine enters Sleep Power state. Permanent changes are written to flash memory. Frequent permanent changes are not recommended due to the limited write-cycles of flash memory.

Do not scan configuration barcodes and send parameters via SCI simultaneously. All parameters can be accessed via SCI, so configuration barcode scanning is not necessary.

9 Glossary

Bar	The dark element in a printed barcode.
Space	The lighter element of a barcode formed by the background between bars.
Barcode density	The thickness of the narrowest element in the barcode (e.g. 5 mil, 10 mil, etc).
Resolution	The narrowest element dimension which can be distinguished by a particular reading device or printed with a particular device or method.
Decode zone	An area within an engine's field of view.
MIL	1 mil = 1 thousandth of an inch, i.e. 0.0254 mm.
Byte	1 byte = 8 bits
Bit	1 byte = 8 bits

10 ASCII table

		for keyboard wedge		for RS-232	
H \ L		0	1	0	1
0		Null		NUL	DLE
1		Up	F1	SOH	DC1
2		Down	F2	STX	DC2
3		Left	F3	ETX	DC3
4		Right	F4	EOT	DC4
5		PgUp	F5	ENQ	NAK
6		PgDn	F6	ACK	SYN
7			F7	BEL	ETB
8		Bs	F8	BS	CAN
9		Tab	F9	HT	EM
A			F10	LF	SUB
B		Home	Esc	VT	ESC
C		End	F11	FF	FS
D		Enter	F12	CR	GS
E		Insert	Ctrl+	SO	RS
F		Delete	Alt+	SI	US

Notes: The 2nd and the 3rd columns above are used for keyboard wedge only.

H \ L		2	3	4	5	6	7
0		SP	0	@	P	`	p
1		!	1	A	Q	a	q
2		“	2	B	R	b	r
3		#	3	C	S	c	s
4		\$	4	D	T	d	t
5		%	5	E	U	e	u
6		&	6	F	V	f	v
7		‘	7	G	W	g	w
8		(8	H	X	h	x
9)	9	I	Y	i	y
A		*	:	J	Z	j	z
B		+	;	K	[k	{
C		,	<	L	\	l	
D		-	=	M]	m	}
E		.	>	N	^	n	~
F		/	?	O	_	o	DEL

Example: ASCII “A” = “41”.

11 Test chart

UPC-A

6 59871 23231 9

UPC-E

0 232310 7

UPC-E1

1 6 5 4 3 2 1 4

EAN-8

0123 4510

EAN-13

1 234567 891019

ISBN/ISSN

9 780194 315104

Code 39

0189-.\$AZ

Code 32

A908765439

Code 128

01AZ[+*/]za98

UCC/EAN 128

01AZ[]+az54

ISBT 128

=1234 56789

Interleaved 2 of 5

0123456789

Industrial 2 of 5
(Default setting: Read disable)

0123456789

Matrix 2 of 5

9876543210

Code 93



01AZ+/*az89

Code 11

(Default setting: Read disable)



123456789-0

MSI/Plessey

(Default setting: Read disable)



0123456789

UK/Plessey



01ABEF89

China Post



54789632145

GS1 DataBar (GS1 DataBar Truncated)



1234567890123

GS1 DataBar Limited



987654321012

GS1 DataBar Expanded



Ab_09+yZ

12 Enable & Disable scanning configuration barcode



***Enable scanning configuration barcode**

The default status of the engine is enabled to scan configuration barcode, and the parameter of Parameter Scanning (0xEC) in [Table 6-1 SE serial standard parameters](#) is set 0x01.



Disable scanning configuration barcode

Scan the above barcode to disable scanning configuration barcode, and the parameter of Parameter Scanning (0xEC) in [Table 6-1 SE serial standard parameters](#) is set 0x00. Then the engine will not operate configuration by scanning configuration barcode, but the data string of configuration barcode will be displayed.

Note: The setting of the above two barcodes does affect the operation of scanning the barcodes in [13 Return default parameters & firmware version](#).

13 Return default parameters & firmware version



WARNING: Load uE serial defaults

If you wish to return the engine to all the factory default settings as uE serial, scan the barcode above.



WARNING: Load SE serial defaults

If you wish to return the engine to all the factory default settings as SE serial, scan the barcode above.



Write to customer defaults

Write current parameter settings to the customer default settings.



Restore uE serial customer defaults

Restore the customer default settings to current settings. If failed, restore the uE serial default settings.



Firmware version list

If you wish to display the firmware version, scan the barcode above.

Note: In the case of the parameter of "Parameter Scanning (0xEC)" in Table 6-1 is set 0x00. When the above barcodes in this section are scanned, only the data string of the above barcodes will be displayed, no configuration operation will be applied.

14 Configuration alphanumeric entry barcode (as Para. value)



To finish parameter setting, please scan the bar code below.



Appendix A: Notes of the substitution of uE serial for SE serial

SE serial scan engine can be substituted with uE serial in most working environments. However, some differences in operation must be noted as listed in Table A-1.

Table A-1 Differences between uE serial and SE serial

Index	Item	Difference		Comments for uE serial
		uE serial	SE serial	
I. Operation				
1	Parameter to change temporarily.	Parameter will be lost when the engine enters Sleep Power state or powers off.	Parameter will be lost only when the engine powers off.	It is not recommended to change parameter temporarily for uE serial. See 7-13 SE_PARAM_SEND for further information.
2	Parameter to change permanently by erasing flash.	The duration of erasing flash is 78ms. During this duration, any command cannot be received.	The duration to erase flash is 38ms. During this duration, commands can be received.	The times of erasing flash are up to 10000 according to MCU specification for uE serial. It is strongly suggested to minimize the times of permanently changing parameter.
3	Beeping and command receiving	During beeping, any command cannot be received.	During beeping, commands can be received.	Read 7-4 BEEP for detailed information. The commands of SE_PARAM_SEND and UE_PARAM_SEND apply the Beep code; see 7-13 SE_PARAM_SEND and 7-25 UE_PARAM_SEND .
4	Wake up method	Any falling edge of Pins WAKE, CTS, TRIG and RXD occurs, or RXD receives 0x00.	Any one of Pins WAKE, CTS and TRIG is low, or RXD receives 0x00.	
5	Wake up time	20ms	8ms	
II. Hardware interface				
6	PWRDWN BPR LED Trigger	IO current: 20mA (Awake Power state), 33uA (Sleep Power state)	unknown	In Sleep Power state , each pin is pulled up by a 100K resistor only.
7	TXD RTS	IO current: 20mA (Awake Power state), 16.5uA (Sleep Power state)	unknown	In Sleep Power state , each pin is pulled up by a 200K resistor only.
III. Parameters				
8	Beeper Volume (0x8C)	Not supported	Supported	uE serial will react like SE serial when such a command is received, but will not take real effect.
9	Beeper Tone (0x91)	Not supported	Supported	

Index	Item	Difference		Comments for uE serial
		uE serial	SE serial	
10	Beeper Frequency Adjustment (0xF0 0x91)	Supported	Not supported	The range is from 1220Hz to 3770Hz, with the typical value at 2500Hz.
11	Aim Duration (0xED)	Not supported	Supported	uE serial will react like SE serial when such a command is received, but will not take real effect.
12	Scan Angle (0xBF)	Not supported	Supported	
13	Trigger Mode (0x8A)	Supported	Supported	uE serial has an individual trigger mode of Alternate (0x05). SE serial has an individual trigger mode of Blinking (0x07).
14	Linear Code Type Security Levels (0x4E)	Not supported	Supported	uE serial has the similar functionality with the parameter name of Multiple Confirm 0404 (See 6-4 Trigger mode & some global settings).
15	Bi-directional Redundancy (0x43)	Not supported	Supported	uE serial will react like SE serial when such a command is received, but will not take real effect.
16	Decode UPC/EAN Supplemental Redundancy (0x50)	Not supported	Supported	
17	Decode UPC/EAN Supplemental (0x10)	Supported partially	Supported	uE serial only supports two options, 0x00 and 0x02, of this parameter. And there is a little bit difference of settings of supplemental of UPC-A, UPC-E, EAN13, EAN8. See 6-6 UPC-A, 6-7 UPC-E, 6-9 EAN13, and 6-10 EAN8 for further information.
18	Length parameter (L1, L2)	Supported partially	Supported	uE serial does not support the case of L1>L2.
19	Baud Rate	Supported partially	Supported	uE serial does not support the baud rates of 300 and 600.
20	Decode Event (0xF0 0x00)	Not supported	Supported	uE serial will react like SE serial when such a command is received, but will not take real effect.
21	Parameter Event (0xF0 0x03)	Not supported	Supported	
22	Decode Data Packet Format (0xEE)	Supported	Supported	uE serial has different associated hexadecimal values for each type of barcode to SE serial. See Table 7-5 in 7-7 DECODE_DATA for detailed information.
23	Other Parameters	Peculiar parameters	-	See 6 Parameter menus for further information.